

TECHNICAL MANUAL



Technical manual

Chromagen is a pioneer in the production of hot water solutions since 1962, with vast experience and a solid presence in over 40 countries around the world, and continuously expanding. Chromagen is positioned within the top 10 largest flat plate collectors' manufacturers world-wide.

At Chromagen, we are proud of our high quality Hot water solutions and long lasting products, using the highest raw material quality, complying with all international standards.

Chromagen's projects department provides complete hot water solution that is tailor made applications for residential and commercial projects.

This technical manual describes and explains essential principles for the Installation and operation of Chromagen's solar thermal systems. The guide provides product range information, specifications and maintenance of Chromagen's systems.

It is designed as a reference guide, a document for basic and advanced training and a support during consultations.



Table of contents

1	Introduction	
	1. Systems introduction.....	8
	2. Quality assurance.....	8
	3. Solar thermal basics.....	8
	4. Forced circulation systems.....	9
	5. Thermosiphon system.....	10
	6. Closed loop and open loop systems.....	11
	7. Water quality.....	12
2	Flat Plate Collectors	
	1. Introduction.....	16
	2. Collectors parts.....	17
	3. Chromagen collectors specifications.....	18
	4. Collector's data sheet.....	19
3	Storage Tanks	
	1. Introduction.....	26
	2. Storage tank parts.....	26
	3. Vertical and horizontal tanks.....	28
	4. Storage tanks' data sheets.....	29
4	Installation: Getting Started	
	1. General information.....	36
	2. Thermosiphon system configuration.....	37
	3. Forced circulation system configuration.....	38
	4. Safety during site inspection.....	38
	5. Review local codes.....	39
	6. Tools and equipment.....	39
	7. Selecting system location.....	40
	8. Roof survey.....	40
	9. Water requirements.....	41
	10. Customer approval.....	41
	11. Work force.....	42
	12. Propylene glycol properties.....	42

5	Thermosiphon System Installation	
	1. Inclined roof installation.....	46
	2. Flat roof installation.....	48
	3. Plumbing.....	51
	4. Filling and testing.....	53
6	Forced Circulation System Installation	
	1. Introduction.....	58
	2. Inclined roof installation.....	58
	3. Flat roof installation.....	59
	4. Collectors field installation.....	60
	5. Location of collectors, tank and system operation.....	60
	6. Anti-freeze protection.....	61
	7. Plumbing.....	61
	8. Electrical connections.....	62
	Troubleshooting and Maintenance	
7	1. Thermosiphon system troubleshooting.....	66
	2. Forced circulation systems troubleshooting.....	66
	3. Maintenance.....	68
	4. Periodic maintenance.....	69
	5. Parts replacement.....	69
	6. Warnings.....	69
	Accessories	
8	1. Thermostatic control.....	74
	2. Circulation pumps.....	74
	3. Thermostatic mixing valve.....	75
	4. Anti-scale filter.....	76
	Warranty	78
	Index	79

1 Introduction



1.1

Systems introduction

Chromagen products may be assembled into four different system types:

- Thermosiphon, close-loop system
- Thermosiphon, open-loop system
- Forced circulation, close-loop system
- Forced circulation, open-loop system

The differences and working principles of the different systems are described in this manual.

Thermosiphon systems are recommended whenever the tank may be located on the roof or beneath the roof, above the third upper part of the collector, and the average ambient temperature doesn't go below 5°C. These systems' operational features are simpler than forced systems' features, as they do not involve any moving parts or electrical pumps. In forced systems, the water storage tank may be located anywhere, which is useful when there are aesthetic considerations, or when the roof structural support cannot hold the weight of a full tank.

1.2

Quality assurance

Chromagen's quality management scheme meets the ISO 9001 standards.

Our products are made from the highest quality raw materials, while modern production lines ensure a consistency of precision and finish. Chromagen systems and components are tested to comply with the European standard EN12975 for solar collectors and EN12976 for solar thermal systems, International standard ISO9806, Israeli standard, SRCC USA, Australian standard and more.

Numerous institutes worldwide have tested and approved Chromagen systems:

Cener Spain, FSEC Florida, ITW Germany, SPF Switzerland, CSTB France, ENEA Italy, Bodycote Canada, SII Israel and others. Chromagen is proud to provide its customers with high quality, efficient products and to be an integral part of the worldwide quest for a cleaner environment by using renewable energy sources.

1.3

Solar thermal basics

A solar water heating system is made up of several important elements:

- One or more solar collectors mounted on the roof
- A storage tank, with or without an inner heat-exchanger
- An electrical pump for circulating the heat transfer fluid (in Forced systems only)

There are two solar water heating circulation types:

- Thermosiphon [TS]
- Forced Circulation [FC]

Forced Circulation systems use electricity to power pumps that move liquid through the system. Thermosiphon systems rely on gravity to move liquid through the system. In both systems, the absorber plate

1.4

Forced circulation system

of the collector gathers the sun's heat energy, which in turn warms the water or the anti-freeze solution that flows through an array of tubes. Once heated, the liquid flows through the tubes to the storage tank. The heated liquid warms the cooler water in the storage tank directly or through a heat-exchanger. A backup energy source, normally electricity or gas, supplies the energy deficit.

FC systems use electrical pumps, valves and controllers to circulate water or other heat-transfer fluids through the collectors. FC systems are usually less efficient and more expensive than TS systems, however they enable high flexibility in the positioning of the systems' components: storage tanks do not need to be installed above or close to the collectors. Since FC systems use electricity to operate the pump, these systems will not function in a power outage.

Forced circulation system - schematic

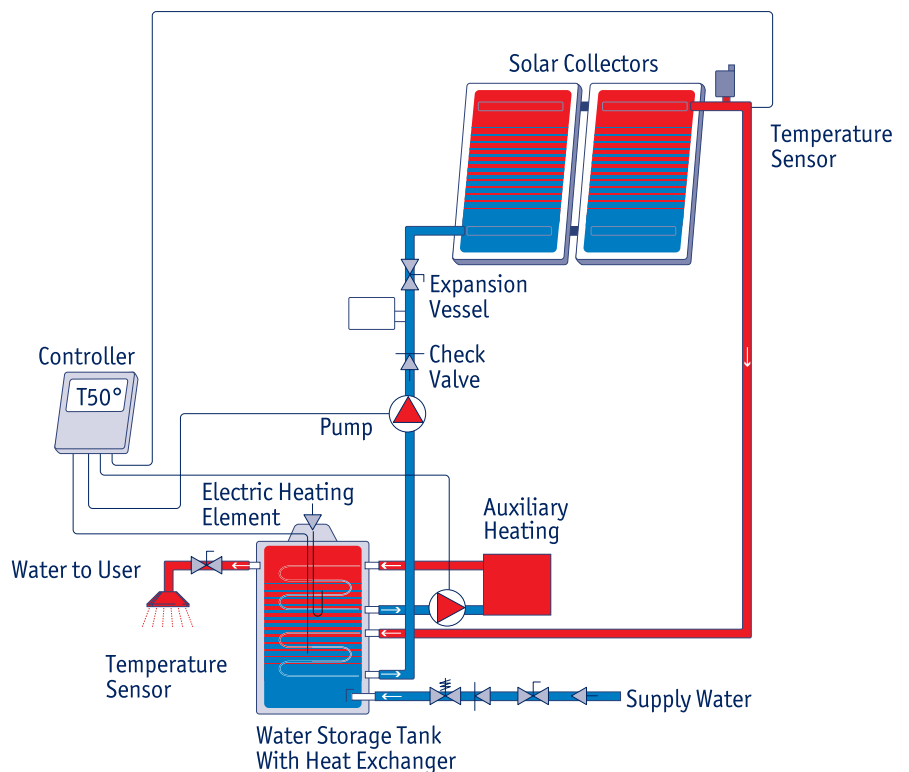

1.5

Thermosiphon system

In general, TS systems do not use electric-powered pumps to move liquid through tubes. Instead, they use the thermosiphon principal. These systems are easier to maintain, less expensive to install and generally more efficient than FC systems. However, they have installation limits since the storage tank must be placed above the upper third part of the collector.

Thermosiphon systems use natural convection to circulate water through the solar collectors. As water in the collectors warms, it naturally rises to the upper part of the collector and from there to the storage tank. At this stage, the thermosiphon action causes the cooler water in the tank to flow down the pipes to the bottom of the collector and naturally circulate throughout the system. The tank may be placed partly below the collector in a low profile configuration as shown.

Low profile installation requires an additional check valve to prevent reverse thermosiphon flow.

Thermosiphon open-loop system - schematic

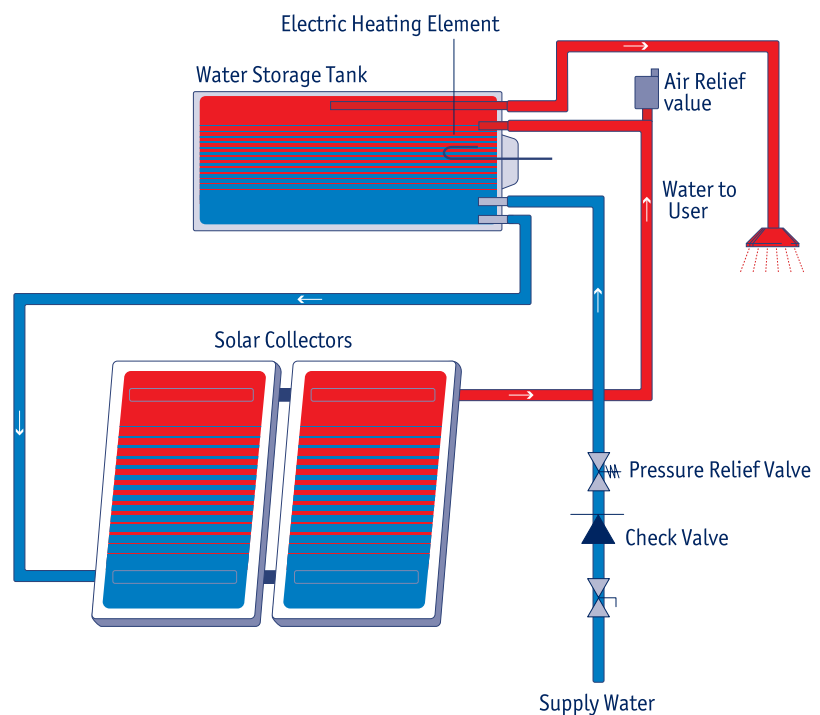

- Tank must be located above the collectors – high profile
- Above the upper third part of the collector – low profile
- Low profile mounting requires additional check valve

Thermosiphon closed-loop system - schematic

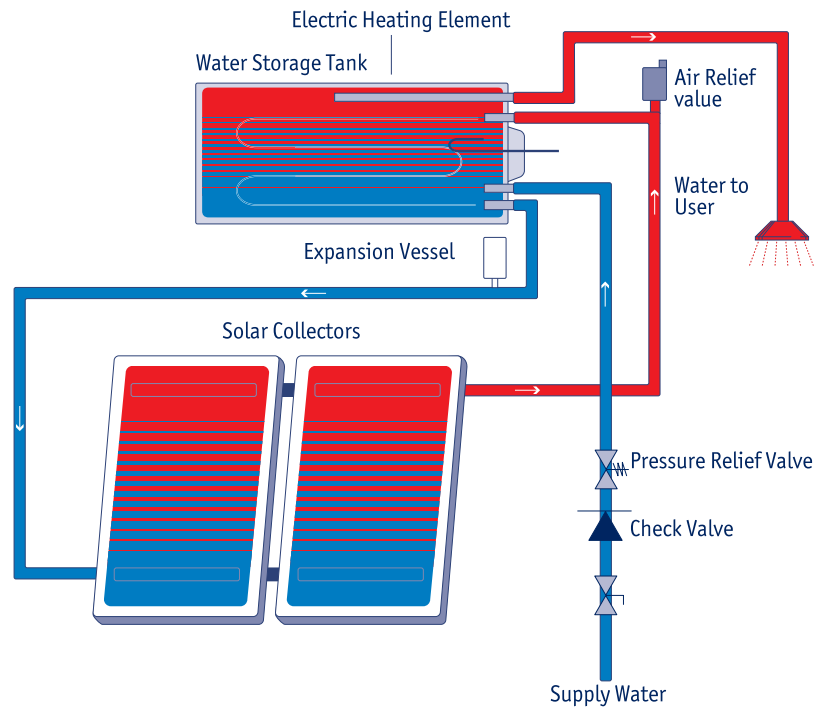

- Tank must be located above the collectors – high profile
- Above the upper third part of the collector – low profile
- Low profile mounting requires additional check valve

1.6

Closed loop and open loop systems

Closed-loop systems

Heat transfer fluid (water or anti-freeze solution) circulates through the system's tubes without mixing with the potable water inside the water storage tank. Closed-loop systems are better-suited for colder climates, since the anti-freeze solution keeps the system from freezing. In places with hard water, the system limits scale development inside the collector's tubes. Closed-loop systems can operate as FC or TS systems.

Open-loop systems

Operate like closed-loop systems with one major difference: anti-freeze fluid must not be used, since the hot water from the collector mixes with the supply water in the storage tank. Open-loop systems are best suited for warm climates; the water can freeze in colder climates and possibly destroy the system. In addition, these systems cannot be used in areas where the water is very "hard" or acidic, since this type of water is likely to corrode or block the system's tubes. Open-loop systems are commonly operated in a Thermosiphon mode.

1.7

Water quality

In regions where calcium carbonate content of water exceeds 250 mg/L (or 250 ppm) it is highly recommended that a closed-loop system is used. Collector clogging from mineral deposits is likely to impair collectors' functionality and shorten systems' life span wherever hard water is used in open-loop systems.





2 Flat Plate Collectors



2.1

Introduction

Solar water heaters use solar collectors to capture the sun heat energy.

When water temperature below 80°C is required, flat-plate collectors are commonly used. A flat-plate collector is an insulated, weatherproofed box containing a dark absorber plate connected to an array of tubes and is covered by a transparent or translucent cover. A collector is typically 1m wide, 2m long and 10cm in depth. The absorber plate gathers the sun's heat energy, which in turn warms the water (or anti-freeze solution) that flows through an array of tubes. Once heated, the liquid is pumped or naturally flows through the tubes to the storage tank. The heated liquid warms the cooler water in the storage tank directly or through a heat-exchanger.

Thermal efficiency

The instantaneous efficiency of a solar collector, operating under steady state conditions, defined as the ratio of the actual useful power extracted, to the solar energy intercepted by the collector, $G \cdot A$.

$$\eta_i = \frac{\dot{Q}}{G \cdot A} \leq 1 \text{ (or 100\%)}$$

Where G is the global solar irradiance on the collector plane and A is the collectors aperture area:

\dot{Q} is calculated from $\dot{Q} = \dot{m}_i C_p (T_{out} - T_{in})$ -

\dot{m} - Flow rate through the collector

C_p - Fluid specific heat

T_{in} - Collector inlet temperature

T_{out} - Collector outlet temperature

Selective surface

The simple black painted surface can be improved and become more efficient by the use of selective coating, and the use of 'sputtering'. Certain special coatings can reduce the re-radiation ability without markably reducing the energy-absorption ability.

Chromagen manufactures solar collectors using state-of-the-art technology.

Aluminum sheet absorber plate is laser welded to copper tubes encased in a frame and covered with tempered solar glass. Absorbers are available with a variety of coating options; selective paint and ultra-selective sputtering. Coated galvanized steel and anodized aluminum cases are available.

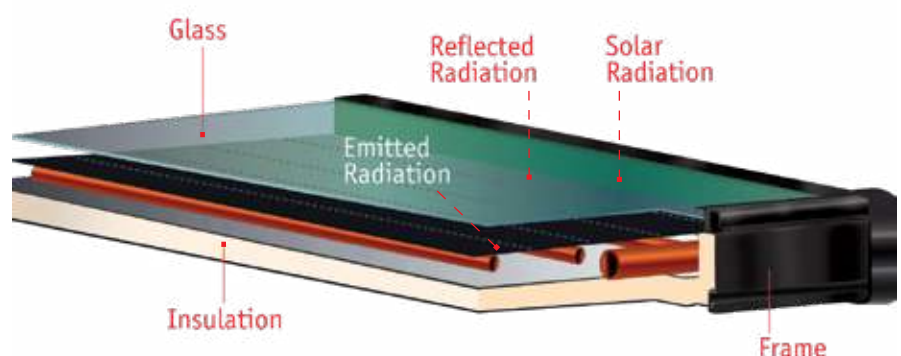

2.2

Collectors parts

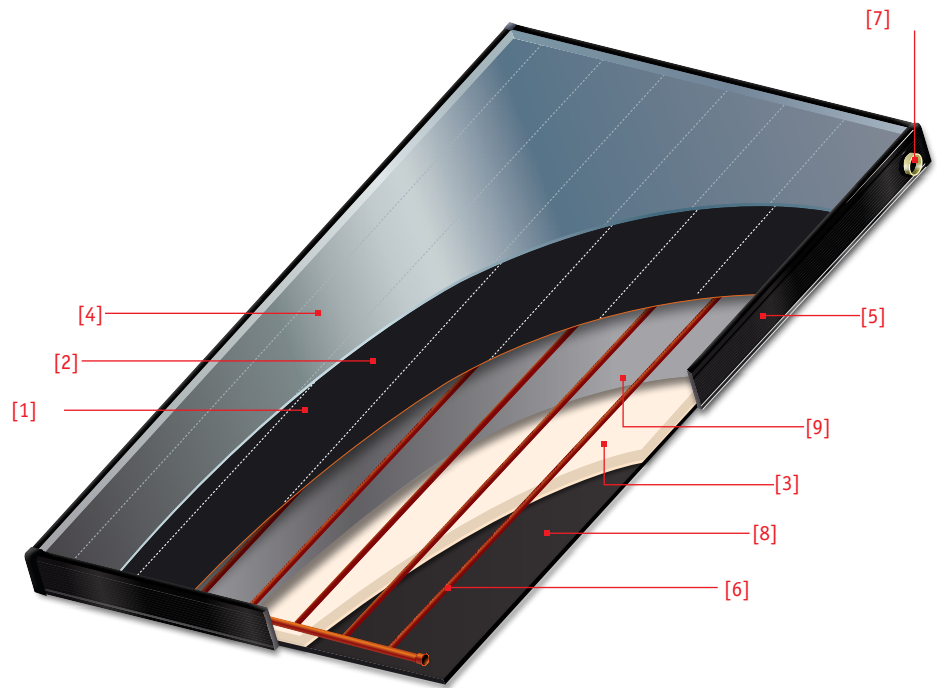

[1] Absorber Plate

Made of aluminum sheet, laser welded to copper tubes, ensuring high efficiency and durability.

[2] Absorber Plate Coating

Selective black paint or ultra-selective sputtered coating with excellent energy absorption and very low energy emission for high performance even in cooler climates.

[3] Insulation

The absorber plate is encased in 23mm rigid, green water based polyurethane foam, with an option for additional layer of glass wool, retaining the collector's heat.

[4] Solar Glass Glazing

The single-pane 3.2mm patterned and tempered solar glass has high solar transmittance of 91% and excellent durability.

[5] Casings

A. All anodized aluminum extrusion casings are made of solid construction available in a natural color.

B. Galvanized steel casings in gray polyester paint finish.

[6] Tubing Grid

16mm or 8mm copper risers brazed to 28mm or 22mm copper manifolds with optimal flow distribution.

[7] Piping Connection

Four 3/4" BSPP female brass adapters.

[8] Back Plate

The back plate is made of black polypropylene sheet.

[9] Aluminum Foil

The aluminum foil, integrated to the insulation, acts as a barrier against out-gassing.

2.3

Chromagen collectors specifications

Chromagen collectors are identified by the coating type, casing type and size.

- Black painted full plate aluminum absorber
- Sputtered aluminum full plate absorber

Each collector may be constructed with aluminum frame or painted galvanized steel frame.

- Anodized aluminum natural color
- Galvanized steel frame - grey painted

Each collector is composed of four models or more, differing in dimension.

Collector size	Y		K		D	
Risers diameter [mm]	8	16	8	16	8	16
Gross area [m ²]	1.41		1.65		2.02	
Aperture area [m ²]	1.25		1.52		1.85	
Length [cm]	181		181		189	
Width [cm]	78		91		107	
Weight [kg]	21	23	26	28	30	33
Fluid capacity [L]	0.8	2.2	1	2.7	1.2	3.2
Thickness [cm]	9					

Collector size	E		F		Z	
Risers diameter [mm]	8	16	8	16	8	16
Gross area [m ²]	2.34		2.77		3.12	
Aperture area [m ²]	2.15		2.56		2.93	
Length [cm]	218		218		246	
Width [cm]	107		127		127	
Weight [kg]	34	37	39	43	46	54
Fluid capacity [L]	1.3	3.6	1.5	4.1	2.1	6.8
Thickness [cm]	9					

- Collector's test pressure: 12 bar
- Maximum collector operation pressure: 8 bar

Coating specifications

Chromagen collectors are identified by the coating type, casing type and size.

	Absorptance α	Emissivity ϵ	Stagnation TEMP. @1000W/m ² & ambient TEMP. 30°C
Selective paint	0.9	0.45	170°C
Sputtering	0.95	0.05	205°C

Glass specifications

	Emissivity ϵ	Transmittance (visible light) τ_{D65}	Transmittance (solar radiation) τ_{SOL}	Thickness t(mm)	Heat conduction K(W/mk)
Solar tempered	0.85	0.916	0.91	3-4	1.04

2.4

Collectors data sheet

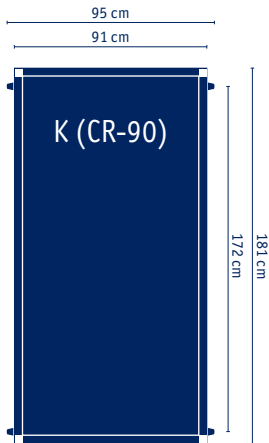

K (CR-90)

Risers diameter [mm/"]	8mm	5/8" (16mm)
Connections thread BSP (female)	3/4"	
Gross area [m ²]	1.65	
Aperture area [m ²]	1.52	
Length [cm]	181	
Width [cm]	91	
Weight [kg]	26	28
Thickness [cm]	9	
Fluid capacity [L]	1	27
Test pressure [bar]	12	
Maximum operating pressure [bar]	8	
Efficiency curve (selective paint)	$\eta=0.69-4.2X$	
Efficiency curve (sputtering)	$\eta=0.74-4.2X$	

Efficiency curve

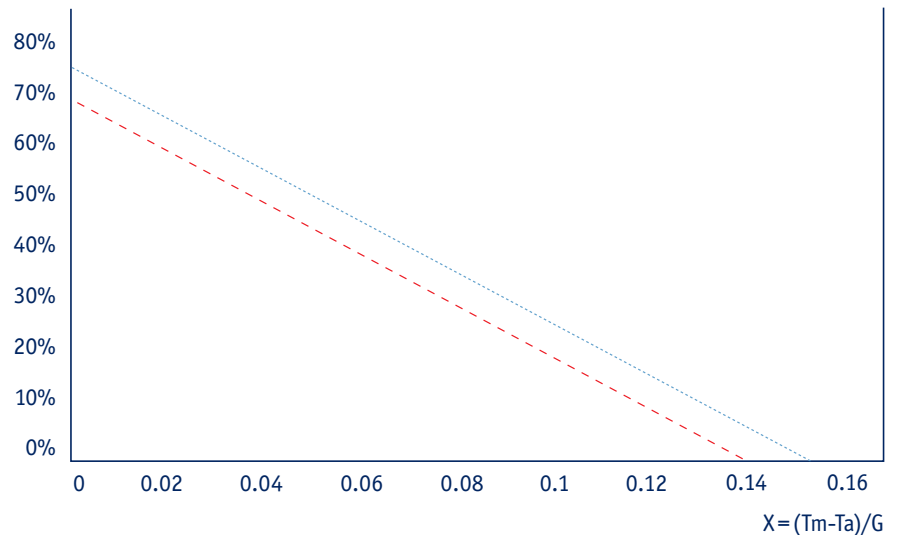

--- Sputtering
 - - - Selective paint

T_m = Water TEMP.: $(T_{out} + T_{in})/2$

T_a = Ambient TEMP.

G = Instantaneous solar radiation

- The attached chart is for comparison purposes
- Efficiency curves based on aperture area

Flow (L / HR)	PRESS. drop on one 16mm COL. (cm of water)	PRESS. drop on one 8mm COL. (cm of water)
50	0.1	0.3
100	0.3	1
150	0.9	2.1
200	1.4	3.5
250	2.5	6
300	3.7	8
350	5.3	10.2

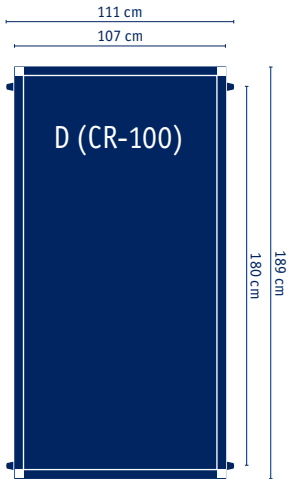

D (CR-100)

Risers diameter [mm/"]	8mm	5/8" (16mm)
Connections thread BSP (female)	3/4"	
Gross area [m ²]	2.03	
Aperture area [m ²]	1.85	
Length [cm]	1.89	
Width [cm]	107	
Weight [kg]	30	33
Thickness [cm]	9	
Fluid capacity [L]	1.2	3.2
Test pressure [bar]	12	
Maximum operating pressure [bar]	8	
Efficiency curve (selective paint)	$\eta=0.69-4.7X$	
Efficiency curve (sputtering)	$\eta=0.75-3.9X$	

Efficiency curve

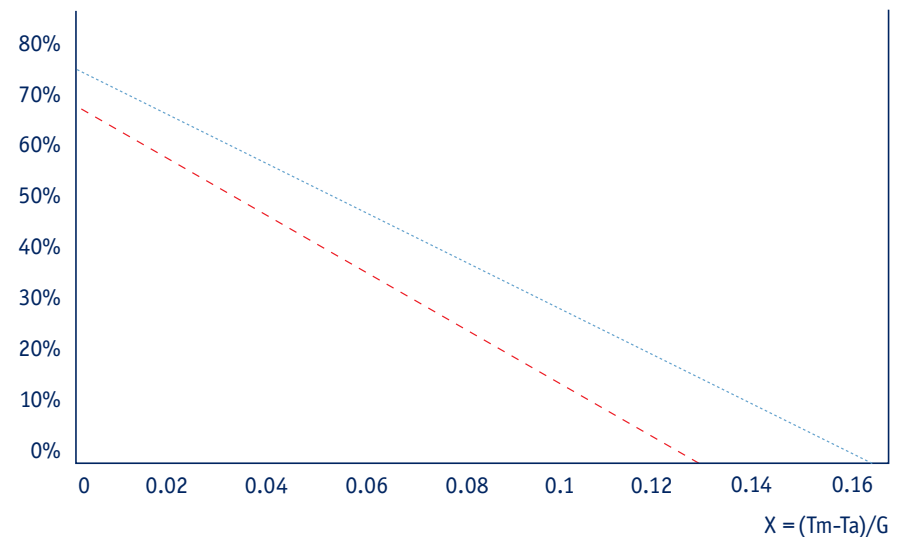

--- Sputtering
 - - - Selective paint

T_m = Water TEMP.: $(T_{out} + T_{in})/2$
 T_a = Ambient TEMP.
 G = Instantaneous solar radiation

- The attached chart is for comparison purposes
- Efficiency curves based on aperture area

Flow (L/HR)	PRESS. drop on one 16mm COL. (cm of water)	PRESS. drop on one 8mm COL. (cm of water)
50	0.2	0.6
100	0.4	0.9
150	1.0	2.5
200	1.5	4
250	2.7	6.3
300	4.0	8.5
350	5.6	10.9

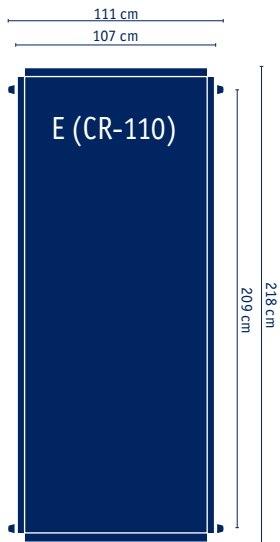

E (CR-110)

Risers diameter [mm/"]	8mm	5/8" (16mm)
Connections thread BSP (female)	3/4"	
Gross area [m ²]	2.35	
Aperture area [m ²]	2.15	
Length [cm]	218	
Width [cm]	107	
Weight [kg]	34	37
Thickness [cm]	9	
Fluid capacity [L]	1.3	3.6
Test pressure [bar]	12	
Maximum operating pressure [bar]	8	
Efficiency curve (selective paint)	$\eta=0.73-4.9X$	
Efficiency curve (sputtering)	$\eta=0.75-3.9X$	

Efficiency curve

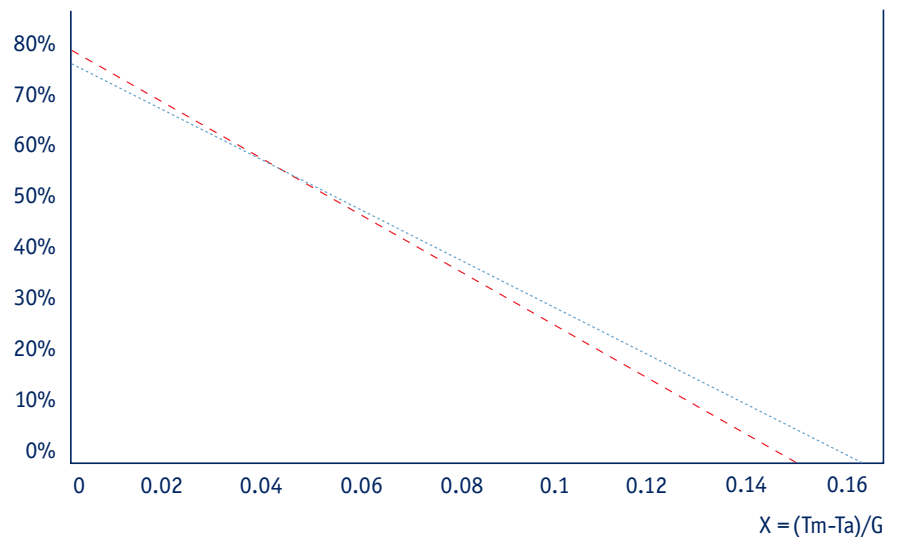

- Sputtering
- Selective paint

T_m = Water TEMP.: $(T_{out} + T_{in})/2$

T_a = Ambient TEMP.

G = Instantaneous solar radiation

- The attached chart is for comparison purposes
- Efficiency curves based on aperture area

Flow (L/HR)	PRESS. drop on one 16mm COL. (cm of water)	PRESS. drop on one 8mm COL. (cm of water)
50	0.25	0.75
100	0.50	1.6
150	1.25	2.6
200	2.00	5
250	3.00	7
300	4.25	8.5
350	5.75	12

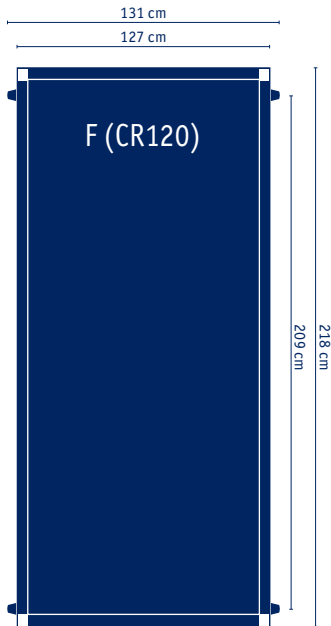

F (CR120)

Risers diameter [mm/"]	8mm	5/8" (16mm)
Connections thread BSP (female)	3/4"	
Gross area [m ²]	2.77	
Aperture area [m ²]	2.56	
Length [cm]	2.18	
Width [cm]	1.27	
Weight [kg]	39	43
Thickness [cm]	9	
Fluid capacity [L]	1.45	4.13
Test pressure [bar]	12	
Maximum operating pressure [bar]	8	
Efficiency curve (selective paint)	$\eta=0.72-4.8X$	
Efficiency curve (sputtering)	$\eta=0.75-3.9X$	

Efficiency curve

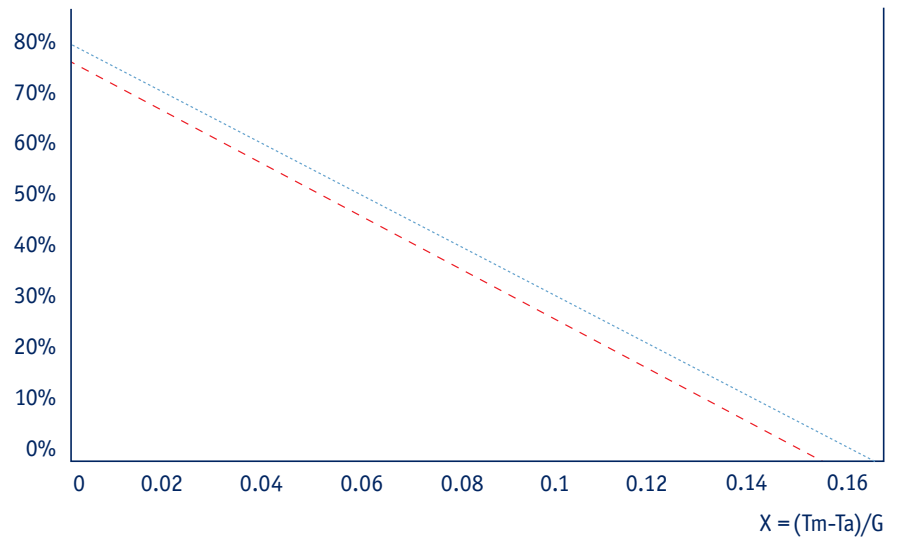

- Sputtering
- Selective paint

T_m = Water TEMP.: $(T_{out} + T_{in})/2$

T_a = Ambient TEMP.

G = Instantaneous solar radiation

- The attached chart is for comparison purposes
- Efficiency curves based on aperture area

Flow (L/HR)	PRESS. drop on one 16mm COL. (cm of water)	PRESS. drop on one 8mm COL. (cm of water)
50	0.4	1.5
100	1	3
150	1.8	4.3
200	3	7.2
250	4.8	9.8
300	6	12.6
350	9	18

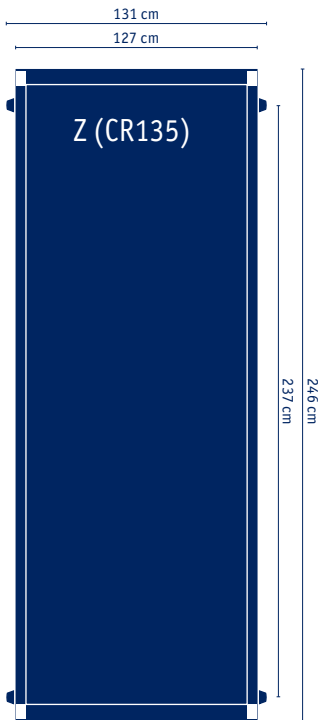

Z (CR135)

Risers diameter [mm/"]	8mm	5/8" (16mm)
Connections thread BSP (female)	3/4"	
Gross area [m ²]	3.12	
Aperture area [m ²]	2.93	
Length [cm]	246	
Width [cm]	127	
Weight [kg]	46	54
Thickness [cm]	9	
Fluid capacity [L]	2.1	6.8
Test pressure [bar]	12	
Maximum operating pressure [bar]	8	
Efficiency curve (selective paint)	$\eta=0.73-4.5X$	
Efficiency curve (sputtering)	$\eta=0.75-4.1X$	

Efficiency curve

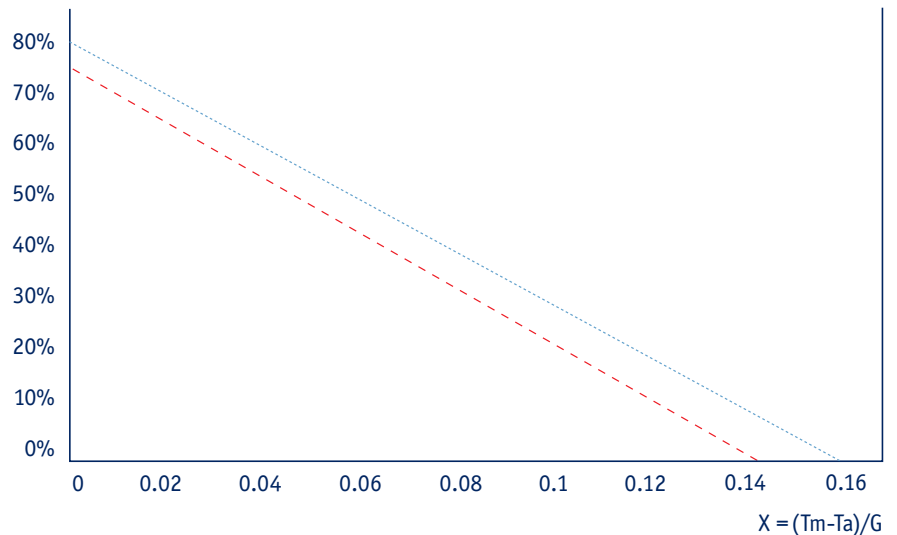

- Sputtering
- Selective paint

T_m = Water TEMP.: $(T_{out} + T_{in})/2$

T_a = Ambient TEMP.

G = Instantaneous solar radiation

- The attached chart is for comparison purposes
- Efficiency curves based on aperture area

Flow (L/HR)	PRESS. drop on one 16mm COL. (cm of water)	PRESS. drop on one 8mm COL. (cm of water)
50	0.6	1.8
100	1.4	3.8
150	2.5	6.3
200	4	8.1
250	6	12.3
300	9	17.7
350	14	25

3 Storage Tanks



3.1

Introduction

Thermo tanks are designed to store hot water for domestic or industrial use. The water inside the tank is heated through several options, as follows:

- **Electrical heating** - using an electric heating element dipped inside the tank
- **Direct heating** - hot water from a solar collector, mixed with tank water
- **Indirect heating** - using a special storage tank that includes a heat-exchanger connected to a water heating source (for example, collector, gas or wood heater)

The storage tank is insulated from the ambient air by a layer of injected polyurethane foam. Chromagen offers a wide selection of water storage tanks with capacity of 30 to 300L. There are seven different types of solar tanks as shown in the following diagrams.

- The horizontal or vertical orientation options enable flexible installation according to customer requirements

3.2

Storage tank parts

1. External coating

Polyester coating provides extreme durability and an attractive finish.

2. Insulation

A thick polyurethane insulation layer ensures optimal insulation and heat retention.

3. Storage tank

Constructed with thick steel, automatically welded, ensuring precision and permitting a working pressure of 8 bar.

4. Enamel coating

An internal glass-enamel layer protects against corrosion.

5. Electric element

Energy efficient electric element with rapid heating time enables the provision of hot water 24 hours a day, 365 days a year.

6. Sacrificial anode

Magnesium Anode provides anti-corrosion protection to the pressure vessel.

7. Thermostat

A built-in thermostat ensures that the water temperature inside the tank does not exceed a preset temperature, while using the electric heating element.

8. Double jacket heat exchanger

9. Cold water inlet

10. Hot water to user

11. Heat exchanger inlet

12. Heat exchanger outlet

13. Heat exchanger safety valve

14. Auxiliary heating inlet*

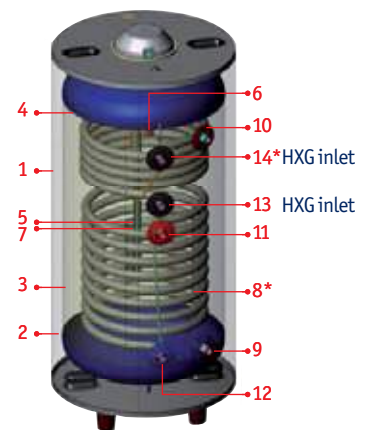

Double Spiral Solar Water Tank

*Specific for this tank only

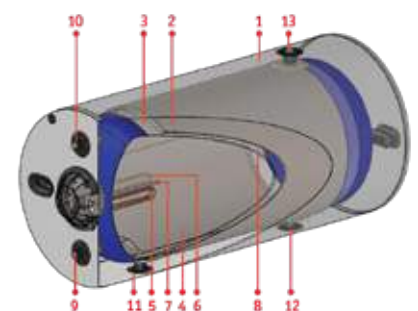

300L horizontal storage tank Double jacket heat exchanger Aluminium external envelope



3.3

Vertical and horizontal tanks

Vertical tanks

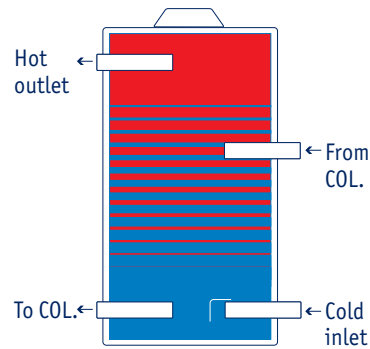

Solar Side Flange (Open - Loop system)

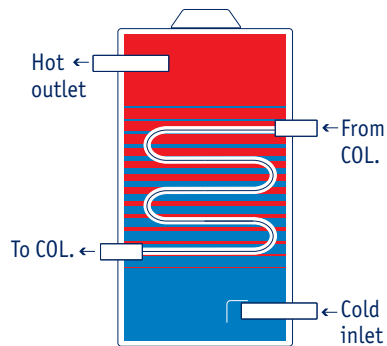

Spiral/ Serpentine Heat-Exchanger (Closed-Loop system)

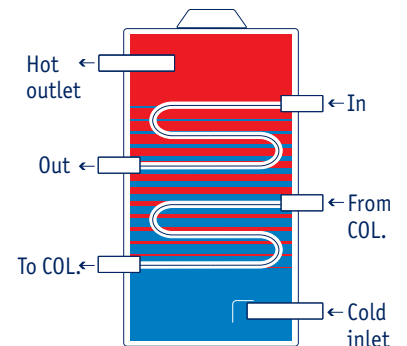

Double Spiral Heat-Exchanger (Closed-Loop system)

Horizontal tanks



Solar (Open-Loop system)

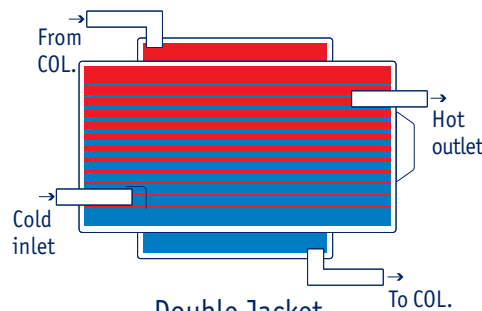

Double Jacket Heat-Exchanger (Closed-Loop system)

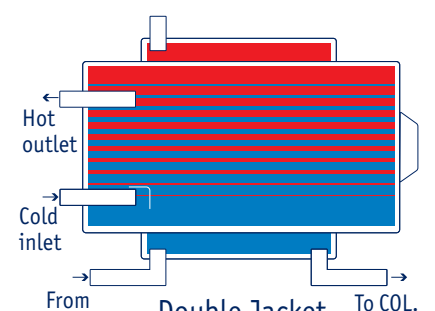

Double Jacket Heat-Exchanger (Closed-Loop system)

3.4

Storage tanks' data

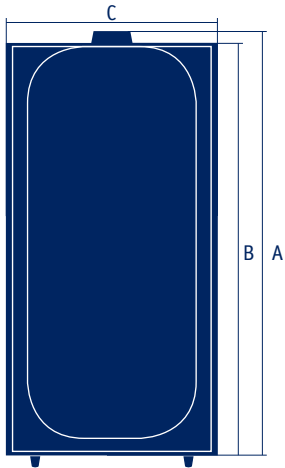

Solar vertical tanks

- [1] External coating
- [2] Insulation
- [3] Storage tank
- [4] Enamel coating
- [5] Electric element
- [6] Sacrificial anode
- [7] Thermostat
- [8] Cold water supply
- [9] Hot water to user
- [10] Hot water from collector - inlet
- [11] Cold water to collector - outlet

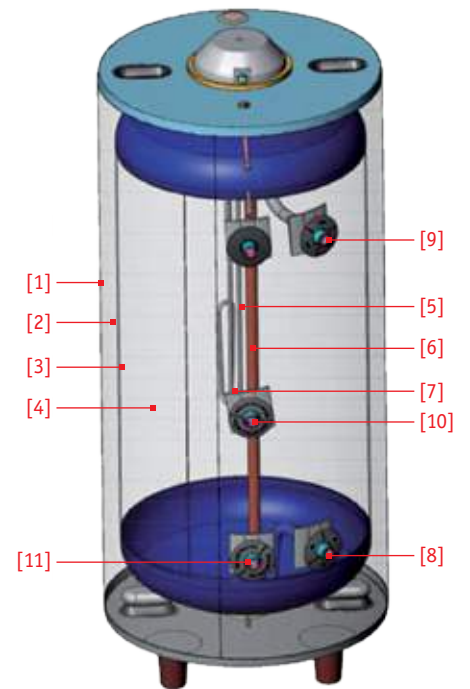

Capacity [L]	A [mm]	B [mm]	C [mm]	Weight [kg]	Electric element (Kw)
150	1,020	950	585	53	2.5
200	1,270	1,210	585	65	2.5
300	1,432	1,372	650	91	2.5

Solar horizontal tanks

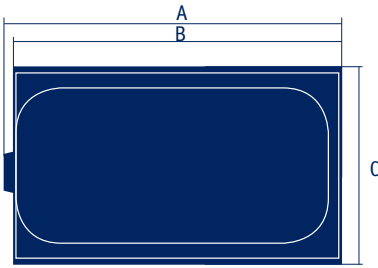

- [1] External coating
- [2] Insulation
- [3] Storage tank
- [4] Enamel coating
- [5] Electric element
- [6] Sacrificial anode
- [7] Thermostat
- [8] Cold water supply
- [9] Hot water to user
- [10] Hot water from collector - inlet
- [11] Cold water to collector - outlet

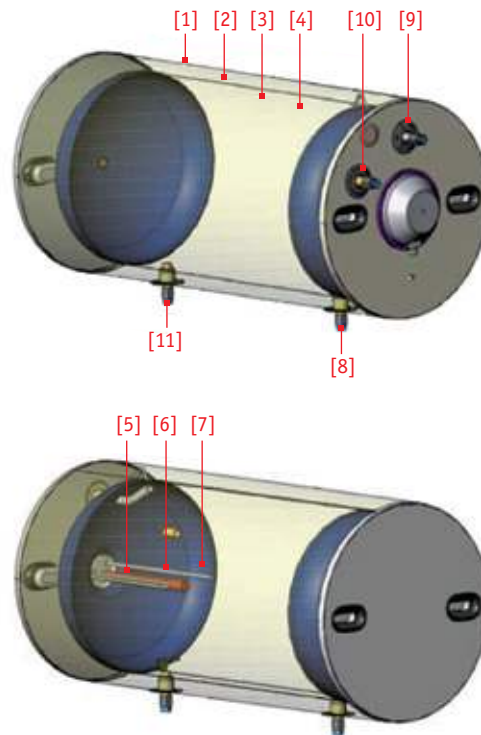

Capacity [L]	A [mm]	B [mm]	C [mm]	Weight [kg]	Electric element (Kw)
120	860	800	560	46	2.5
150	1,020	950	560	53	2.5
200	1,270	1,210	560	65	2.5
300	1,432	1,372	650	91	2.5

Solar tanks with Double-Jacket Heat-Exchanger

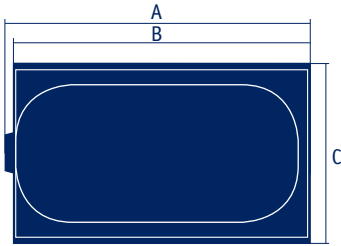

- [1] External coating
- [2] Insulation
- [3] Storage tank
- [4] Enamel coating
- [5] Electric element
- [6] Sacrificial anode
- [7] Thermostat
- [8] Cold water supply
- [9] Hot water from collector - inlet
- [10] Hot water to user
- [11] Cold water to collector - outlet
- [12] Double jacket heat exchanger

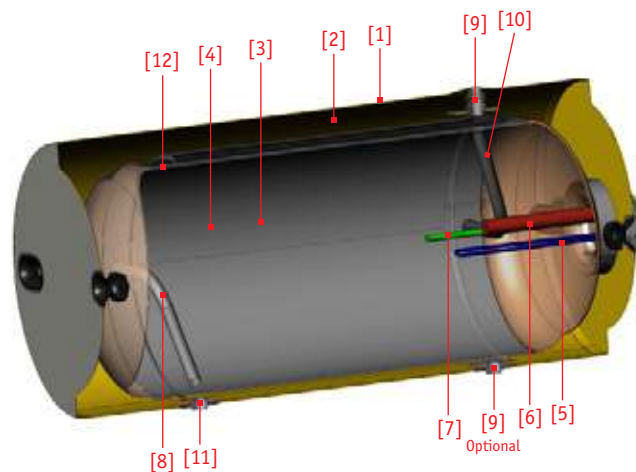

Capacity [L]	A [mm]	B [mm]	C [mm]	Weight [kg]	Electric element (Kw)	Heat-exchanger area [m2]	Heat-exchanger Vol. [L]
120	1,260	1,185	477	74	2.5	0.9	7.5
150	1,020	950	585	75	2.5	0.8	6.5
200	1,270	1,210	585	93	2.5	1.2	9.5
300	1,432	1,372	690	133	2.5	1.6	12.5

Solar vertical tanks with Spiral Heat-Exchanger



- [1] External coating
- [2] Insulation
- [3] Storage tank
- [4] Enamel coating
- [5] Electric element
- [6] Sacrificial anode
- [7] Thermostat
- [8] Spiral heat-exchanger
- [9] Cold water inlet
- [10] Hot water to user
- [11] Heat-exchanger - inlet
- [12] Heat-exchanger - outlet

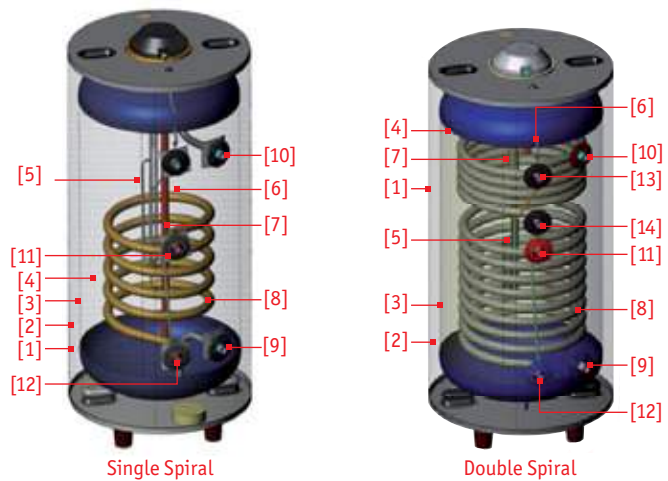

Capacity [L]	A [mm]	B [mm]	C [mm]	Weight [kg]	Electric element (Kw)	Main HXG. area [m ²]	Main HXG. Vol. [L]
120	860/1260	86/1185	585/477	74/76	2.5	0.6	3.3
150	1,020/1,480	950/1,415	585/477	75/78	2.5	0.6	3.3
200	1,270	1,210	585	93	2.5	0.6	3.3
200 Double Spiral	1,270	1,210	585	108	2.5	0.6	3.3
300	1,432	1,372	650	133	2.5	0.9	5
300 Double Spiral	1,432	1,372	650	145	2.5	1.2	6.5



4 Installation: Getting Started



4.1

General information

[1] Safety precautions - read carefully BEFORE installation.

This manual contains easy-to-follow instructions for the correct installation, activation and function of Chromagen domestic solar water heating systems.

Please take your time to understand the system and its parts; it will ensure a successful and trouble-free installation. If you have any questions regarding this installation, contact your Chromagen agent. When working on or around your roof, take care to avoid hazards such as electrical wires and loose shingles/tiles. Use extreme caution when using a ladder or when walking on the roof. Safety always comes first!

[2] The information provided in this manual is general.

System installations in different locations might require a different emphasis. Please consult with a Chromagen representative if any doubt arises.

[3] Brass fittings must not be connected directly to the tank pipes to prevent galvanic corrosion. Steel sacrificial adapter or dielectric fitting must be used.

[4] Lightning protection is based on the connection of the system's metal tubing to common grounding in order to provide the easiest path for lightning to pass to the ground.

[5] Remember that the system components may be damaged if not handled properly. Take extreme care when loading, unloading, transporting or lifting to the roof.

[6] For safety reasons a system should be provided with blow-off lines wherever steam or hot fluid can escape.

120L system	150L System	200L system	300L system
Tank: 120L/32GL	Tank: 150L/40GL	Tank: 200L/53GL	Tank: 300L/80GL
Collector: 1xD / CR100 (1.85 m ²) or 1xK / CR90 (1.52 m ²)	Collector: 1xE / CR110 (2.15 m ²) or 1xD / CR100 (1.85m ²)	Collector: 1xF / CR120 (2.56 m ²)	Collector: 2xE / CR110 (4.03 m ²) or 2xD / CR100 (3.07m ²)

4.2

Thermosiphon system configuration

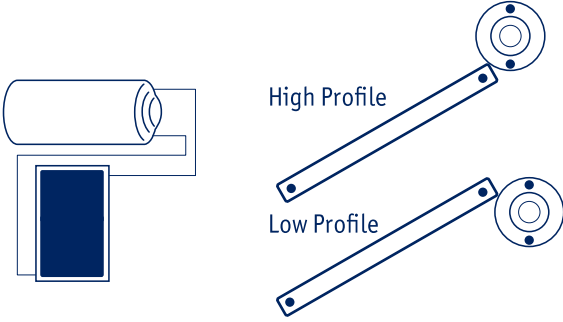
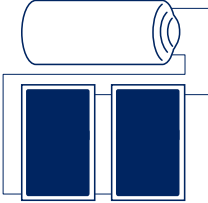
Storage tank Vol.	Collector type	
120 L	1xK / CR90 or 1xD CR100	 <p>High Profile</p> <p>Low Profile</p>
150 L	1xD CR100 or 1xE CR110	
200 L	1xF CR120	
300 L	2xD CR100 or 2xE CR110	

In case of more than 10m total pipe length between the tank and collector, a compensation of 50[Kcal] or 0.058[Kw] for every extra meter per day is recommended.

$$Q_m = v \cdot q_s + (L - 10) \cdot q_p$$

4.3

Forced circulation system configuration

Storage tank Vol.	Storage tank type	Collector type	
120 L	D.J. / Spiral	1xK (CR90) or 1xD (CR100)	
150 L	D.J. / Spiral	1xD (CR100) or 1xE (CR110)	
200 L	D.J. / Spiral	1xF (CR120)	
300 L	D.J. / Spiral	2xD (CR100) or 2xE (CR110)	

- Different configurations or different absorbers might be needed in different global locations
- For accessories, plumbing and mounting parts review chapters 5, 6 and 8
- Dimensions, weight and other properties of solar collectors can be found in chapter 2
- Dimensions and weight of solar, double jacket and spiral tanks can be found in chapter 3
- Supply line recommended pressure: 4-6 bars
- Thermostat maximum temperature setting: 60°C (140°F)

4.4

Safety during site inspection

- Always exercise extreme caution when working on or around a roof
- Be sure to secure ladders so that they do not slip or fall
- Wear shoes with proper tread to prevent slipping
- Disconnect all electric power when installing the control system and pumps
- Always consult with the proper authorities or check with your local building department for requirements and applicable codes before starting the job

4.5

Review local codes

Review:

- Area requirements
- Plumbing requirements
- Roof support stress load and modification requirements, (including engineering review, if necessary)

Obtain building plans, if possible, to help locate bearing walls/columns/ beams, and determine truss strength.

Record extreme weather conditions:

- Heavy snowfall areas require a roof-ridge mount
- High-wind areas require an additional bracing kit
- Installation sites subject to winds of more than 50mph require a specially engineered mounting rack

4.6

Tools and equipment

Basic plumbing supplies	Carpentry supplies
Standard tools: pliers, cutters, hammers, saw, screwdrivers, metric and American wrenches	5x10x240cm (2x4x96") redwood or treated wood runners as required
12" pipe wrench	Masking/duct tape
Adjustable - crescent wrenches	Waterproof sealing compounds
Water pressure gauge	M8/5 /16" lag bolts, length 2",3",4",6" as required
Copper tubing tools	Nails, 10cm (16d -3.5") or assorted as required
Caulking gun	Silicone sealant
24" spirit level	Wood/sheet metal screws and washers
Measuring tape	
Extendable ladder	
½" electric drill with bits	
Skill saw with standard and masonry blades	

4.7

Selecting system location

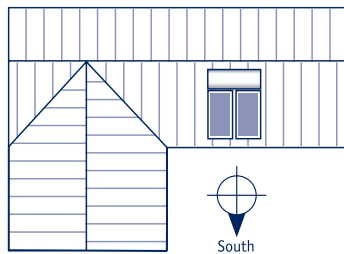
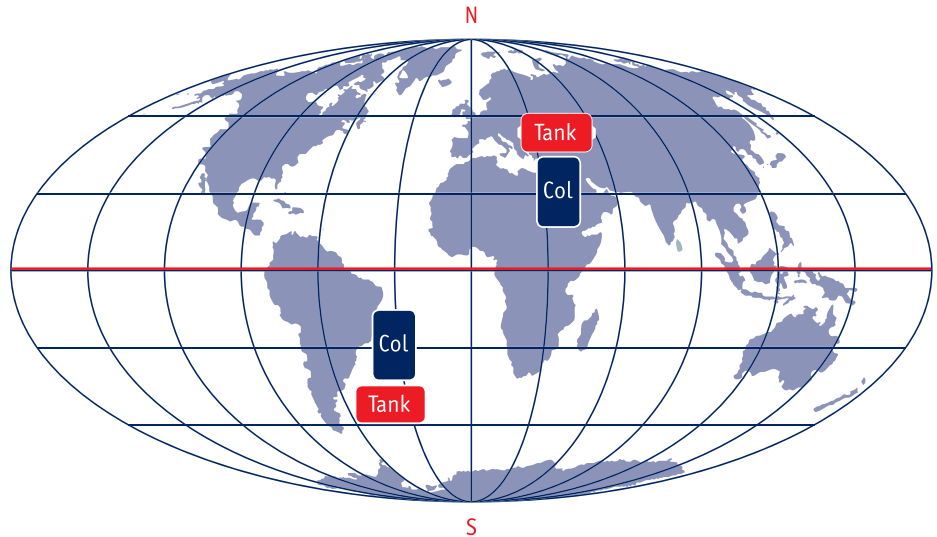

Northern Hemisphere Positioning

- System must face south when installed in a northern hemisphere location
- System must face north when installed in a southern hemisphere location
- Deviation of 30° to each side is acceptable
- Site must be shade-free all year round and clear of obstructions

4.8

Roof survey

Record the following on your pre-installation survey:

- Type of roofing material (tile, shingle, tar & gravel, metal, etc.)
- Roof condition. Note repair requirements

Note: Roofs in poor condition may need replacement before installation.

Using the following table, select the appropriate supporting structure:

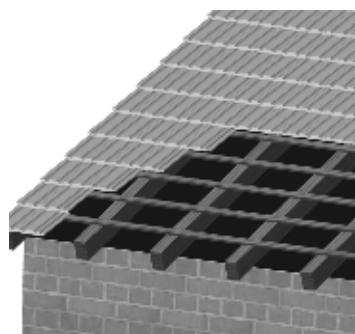

Tile roof structure

Roof type	Supporting structure
Inclined roof	TS system inclined roof rack
	FC system collectors rack
Flat roof	TS system universal flat roof stand
	FC system flat roof collectors rack

Installation tilt-angle

Flat solar collectors must be tilted at an angle (to the horizontal surface) that is approximately equal in degrees to the local latitude. Since the sun is lower on the horizon during the winter months, tilting the collector at an angle of up to 15 degrees, greater than latitude, increases winter performance, which is desirable in most cases.

Roof support requirements

The 300L (80GL) system weighs 475kg (1,140lbs) when installed and filled, therefore it might be necessary to provide additional roof support. You must inspect the roof support system to determine if additional bracing is needed.

4.9

Water requirements

Water quality

City water is a controlled water source and should not cause any difficulty with the system. Some water may have elevated mineral content and require more frequent system maintenance. For additional information review section 1.7.

Water pressure

Water pressure range of 1-6 bars (15-87 psi) is required for a correct operation. Pressure above 6 bars (87 psi) requires the installation of a pressure regulator on the main supply.

Notes

- All plumbing installation must conform to local codes
- All piping must be adequately supported: supports must conform to local codes
- All piping must be adequately insulated: insulation must conform to local codes
- All piping must slope towards a drain
- Plumbing must be installed in a manner that minimizes flow resistant

4.10

Customer approval

Suggested customer procedures:

- Review installation point with the customer
- Ensure that the customer signs the job approval form

4.11

Work force

The empty 300L (80GL) tank weighs 130kg (290lbs) and special provisions are required to lift it to the roof. In some cases a crane is needed to place the tank on its rack. Only a qualified electrician should install all electrical wiring. Professional installation is essential to the reliable operation of a solar system. Installers should be specialists in the planning and installation of solar water heating systems.

4.12

Propylene glycol properties

For anti-freeze protection of closed-loop solar systems anti-freeze liquid is filled, containing a certain percentage of propylene glycol solution according to the lowest ambient temperature predicted.

Concentration by volume	Propylene glycol freezing point
55%	-40°C (-40°F)
50%	-33°C (-28°F)
40%	-25°C (-13°F)
30%	-16°C (+4°F)
20%	-8°C (+17°F)

Notes

- Concentration of 40% to 50% glycol is accepted as a standard in central Europe
- Anti-freeze protection is essential, as a single freeze event can destroy a collector. Even in warm areas, collector tubes have frozen and burst during hard winter freezes
- The Food and Drug Administration (FDA) has determined propylene glycol to be “generally recognized as safe” for use in food, cosmetics, and medicines
- Corrosion is usually minimized by using pH control and corrosion inhibitor use; however, corrosion problem are unlikely to occur in air-free closed circuit systems



5 Thermosiphon System Installation



5.1

Inclined roof installation

- [1] Mark supporting rafter/truss and bearing-wall/column/beam locations on roof
- [2] Mark the tank location on the roof
- [3] Remove the tiles and place four metal bases on the roof truss with 8x60mm lag bolts
- [4] Place the tiles back in place and seal holes, if any were made
- [5] Place the system metal frame over the bases and secure the frame to the bases with 10mm bolts
- [6] Position and secure the tank to the cradle; **Remember that the tank is heavy and needs special care**
- [7] Position the collectors in place and secure them by using the supplied brackets
- [8] Connect the solar collectors between them (if two or more are used), using a 3/4" brass union
- [9] Connect the flexible pipes between the tank and the collectors to ensure continuous slope toward the tank
- [10] Fill the water tank with water and make sure there is no leakage
- [11] Fill the closed-loop with anti-freeze, purge air and make sure there is no leakage

Inclined roof rack parts

TS 150/200 L inclined roof stand parts		
Part no.	Description	Quantity
MXMAMZV100	Front leg telescopic 1	2
MXMAMZV105	Front leg telescopic 2	2
MXMAMZV155	Upper bar 200	1
MXMAMZV150	Collector ruler 200	1
MXMAMZV120A	Tank support 1	2
MXMAMZV120B	Tank support 2	2
MXMAMZV122	COL. securer 45°	2
MXMAMZV145	Tension bar - DIAG. 200	1
MXMAMZV100	Leg base	4
	Bolt 8x15 M	18
	Nut 8 M	16
	Bolt DIN 7991 8x20 M	2

TS 150/200 L inclined roof stand parts

Install the system rack as shown in the drawings:

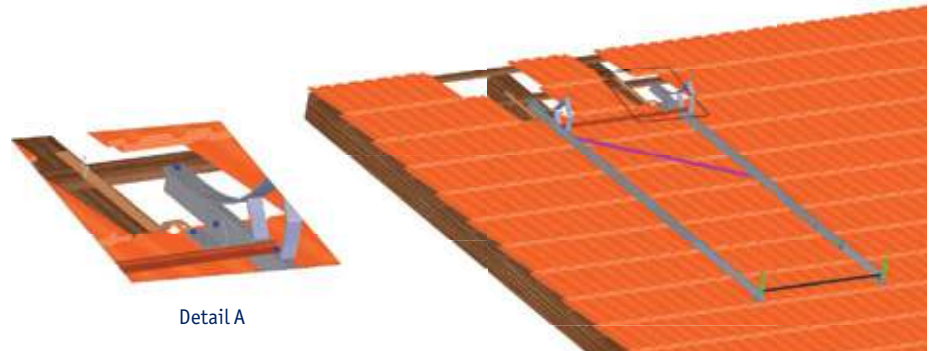

Detail A

- Use a mold to set the location of the bases in accurate position

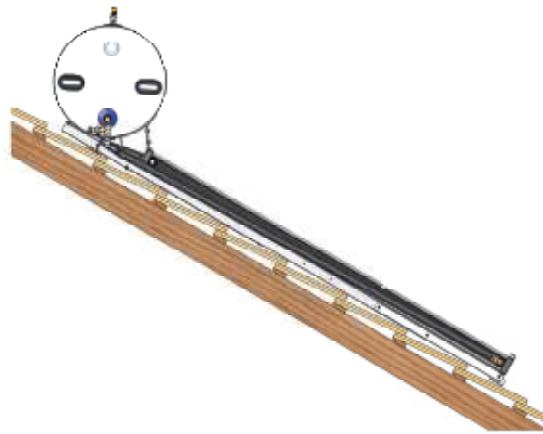

5.2

Flat roof installation

- [1] Mark supporting rafter/ truss and bearing-wall/column/beam locations on roof
- [2] Mount and position the stand on provisions made for the stand in the flat roof
- [3] Position and secure the tank on the cradle; **Remember that the tank is heavy and needs special care**
- [4] Position the collectors on the stand and secure them by using the supplied brackets
- [5] Connect the solar collectors between them (if two or more are used), using a $\frac{3}{4}$ " brass union
- [6] Connect the flexible pipes between the tank and the collectors to ensure continuous slope toward the tank
- [7] Fill the water tank with water and make sure there is no leakage
- [8] Fill the closed-loop with anti-freeze purge air and make sure there is no leakage

Flat roof stand – low profile installation

(Upper 1/3 section of the collector)



Parts for 150 L & 200 L stands 30° & 45° mounting:

Part no.	Description	MAXFH1F30 200L-30° QTY.	MAXFH1F45 200L-45° QTY.	MAXFH2E35 300L-35° QTY.
PBRAGV060	Zin plated nut M8	30		
PBRAGV040	Hex. cap screw 5/16-18	28		
PBRALN100	Screw, socett flat head M8	2		
MXMAMZV100	Front leg TLSCP	1	2	
MXMAMZV100A	Front leg TLSCP	1		
MXMAMZV105	Front leg TLSCP	2	2	
MXMAMZV110	Upper bar 150			
MXMAMZV115	Collector ruler 150			
MXMAMZV120	Tank support	2		
MXMAMZV120A	Tank support 1		2	
MXMAMZV120B	Tank support 2		2	
MXMAMZV122	Collector and tank securer		2	
MXMAMZV125	Rear leg 150-30			
MXMAMZV126	Rear leg 150-45			
MXMAMZV130	Tension bar	4	2	
MXMAMZV131	Short tension bar		2	
MXMAMZV135	Leg base	4	4	
MXMAMZV140	Rear leg	2		
MXMAMZV141	Rear leg		2	
MXMAMZV145	Tension bar - DIAG.	1	1	
MXMAMZV150	Collector ruler 200			
MXMAMZV155	Tension bar	2	2	
MXMAMZV160	Collector securer	2	2	
MAXMAMZV270	Rear leg			2
MAXMAMZV275	Front leg TLSCP			2
MAXMAMZV280	Front leg TLSCP			2
MAXMAMZV185	Upper / lower ruler			2
MAXMAMZV290	Short tension bar			2
MAXMAMZV135	Leg base			4
MAXMAMZV195	Tension bar			3
MAXMAMZV300	Tank support			2
MAXMAMZV310	Collector support			2
MAXMAMZV320	Cradle			2

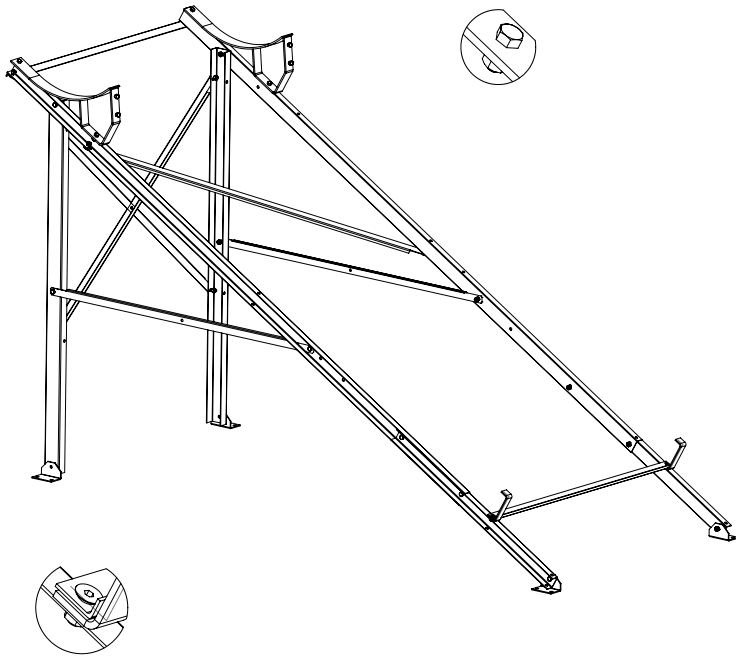

- For detailed drawings of other models such as low profile stands, please contact your local Chromagen agent

5.3

Plumbing

Thermosiphon open loop system

Use the fittings and accessories supplied with the system. Install the system according to one of the following installations possibilities:

Part no.	Description	IKITOL0010 QTY.	IKITOL0020 QTY.
IZAVBR0030	Brass steel elbow 3/4"	2	2
IMAAST0080	Sacrificial element adapter 3/4"	1	1
ISHSAL0010	Brass check valve 1/2-3/4"	1	1
IBRZFF0010	Ball valve 1/2"	1	1
ISHSBI0021	1/2" x 1/2" solar safety valve	1	1
IMAHB00027	Brass 3/4" M 16mm copper tube connector	4	4
IMUFGN0070	Galvanized coupling	3	3
QPKKBR0341	3/4" M brass plug for collectors	2	2
ITZIC00010	Copper pipe 16mm with insulation	4m	4m
IATAMI0020	Klinger gasket	1	1
IRECBR0010	Brass union 3/4"		2

IKITOL0010 – Kit for one collector

IKITOL0020 – Kit for two collectors

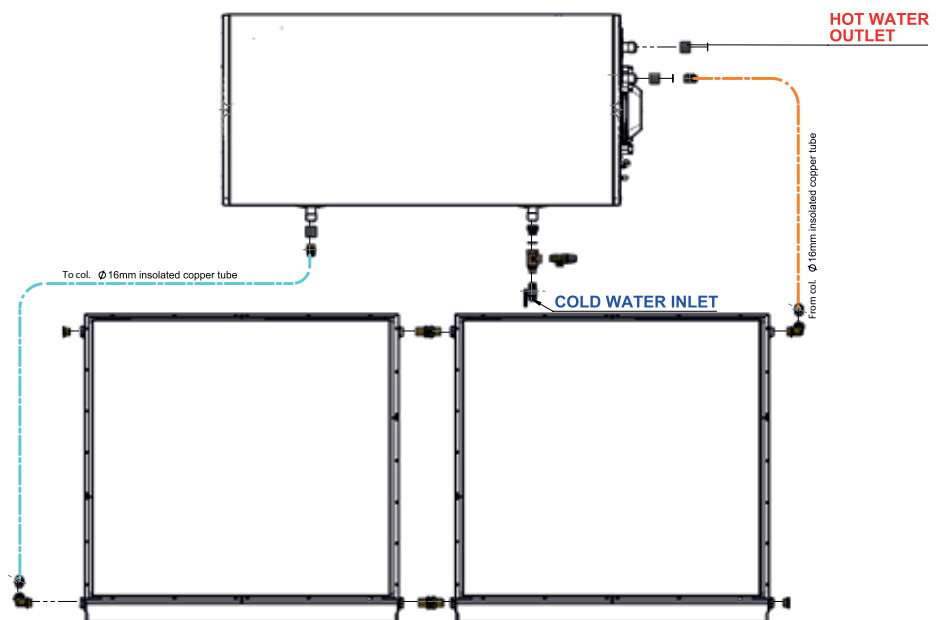

Thermosiphon closed-loop system

Part no.	Description	IKITCL0370 QTY.	IKITCL0380 QTY.
IZAVBR0030	Brass street elbow 3/4"	4	4
ISHSAL0010	Brass check valve 1/2-3/4"	1	1
ISHSBI0021	1/2x1/2" Solar 110°C safety valve 8 bar	1	1
IBRZFF0010	Ball valve 1/2" F-F	1	1
IMAHBO0027	Brass 3/4" M 16mm copper tube connector	4	4
QPKKBR0341	3/4" M brass plug for collectors	1	1
INIPGV0160	Sacrificial 1/2" nipple	1	1
ISHSBI0015	3/4x1/2" safety valve 3 bar	1	1
IZAVBR0020	Brass elbow 3/4" M-M	2	2
IBRZMF0200	Filling unit valve	1	1
IBSHGV0010	3/4-1/2" galvanized bushing	1	1
IMAAST0080	Sacrificial element adapter 3/4" M-F	2	2
IATAMIO020	Klinger gasket flat for valve	1	1
IRECBR0010	Brass union 3/4"		2

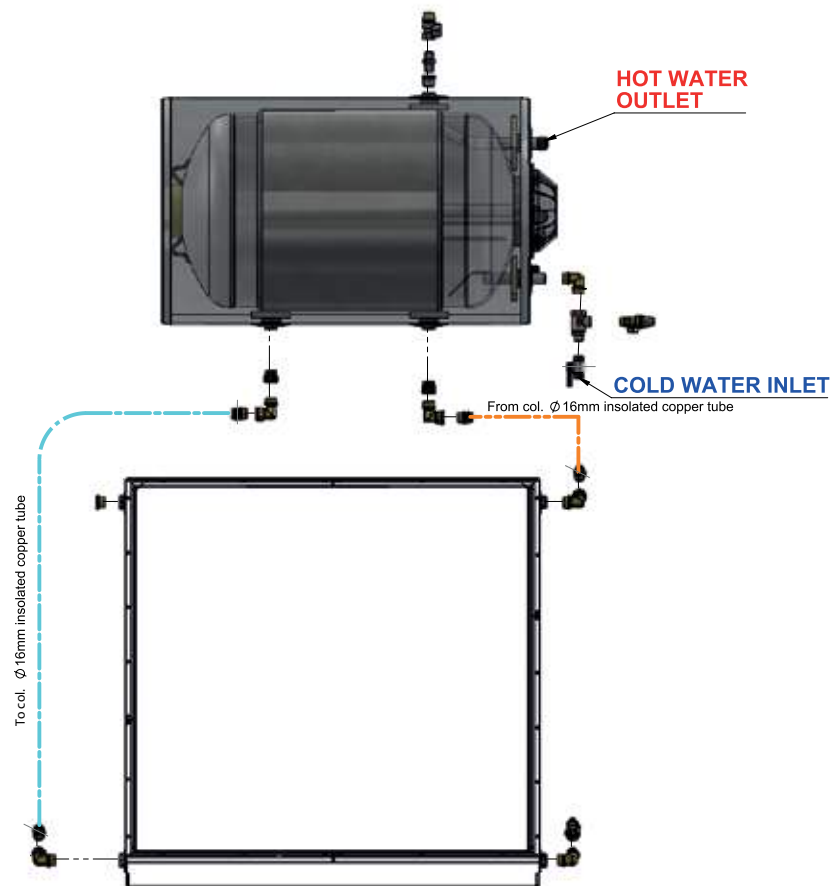

IKITCL0370 – Kit for one collector
 IKITCL0380 – Kit for two collectors

- For safety reasons a system should be provided with blow-off lines wherever steam or hot fluid can escape

5.4

Filling and testing

Filling procedure

Important: in a double-jacket tank, ensure that the solar storage tank is filled and pressurized before filling the double mantle.

- [1] Make sure that all system connections are fastened and that the tank is leveled
- [2] Connect the tank to the main water supply and fill with potable water
- [3] Remove the heat-exchanger air relief valve
- [4] Connect the anti-freeze filling pipe to the filling valve
- [5] Fill the closed-loop with anti-freeze solution until all the air is purged out of the collector loop and it is completely filled
- [6] Return to place the air relief valve
- [7] Pressurize the closed loop to 3 bar and make sure all the air is purged
- [8] Test for possible leaks and repair, if needed
- [9] Lower the collector loop pressure to a working pressure of 2-3 bars by purging water from the air relief valve

Notes

- Prepare 10-20L of anti-freeze solution in cold climate depending on the heat-exchanger type and size. (See anti-freeze solution table in section 4.12; See collector volume in chapter 2; See heat-exchanger volume in chapter 3)
- The system operates properly only when the internal heat-exchanger is fully filled with liquid. Air in the system might hinder the thermosiphon action. Check carefully for leaks and tighten all fittings (re-checking is recommended every 6 months)
- Recommended closed loop working pressure is 2 bar for Double-Jacket and 3 bar for spiral heat-exchanger
- It is necessary to install a pressure reduction valve if the water supply pressure exceeds 6 bars
- There is no provision for the collection of water in case of leakage from the tank - seal or fitting failure. Consider installing a pile with draining pipe under the tank
- Local codes might require the installation of a tempering (mixing) valve between the hot water outlet of the tank and the main hot water supply pipe to the house. The tempering valve should be regulated to 50°C
- For safety reasons a system should be provided with blow-off lines wherever steam or hot fluid can escape

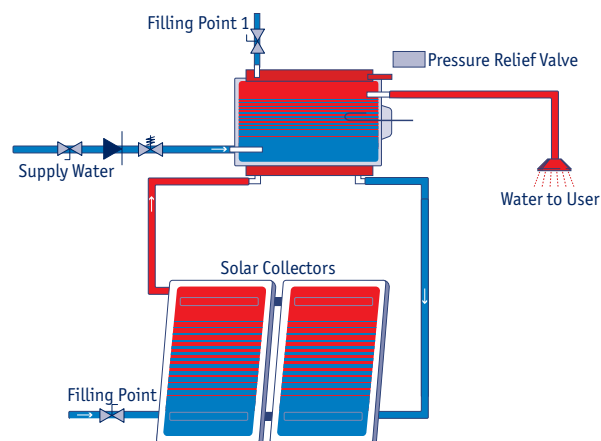





6 Forced Circulation System Installation



6.1

Introduction

Forced circulation systems should be used whenever the storage tank cannot be installed above the collectors as described in chapter 2. The circulating pump is operated by a differential thermostatic control. The basic elements of this system are:

- Solar collector/s
- Storage tank
- Circulation pump
- Differential thermostat
- Sensors
- Expansion tank
- Valves and accessories

The elements in this system simulate the thermosiphon phenomena.

6.2

Inclined roof installation

Collectors' S nails MSM0200K – MSM1100K

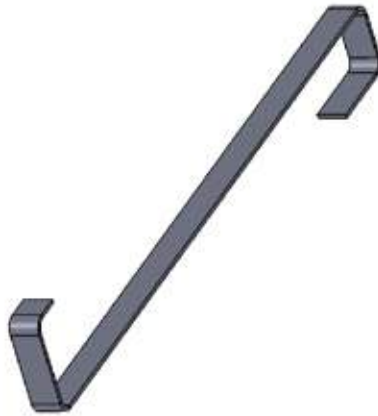

Part no.	H (mm)	Flat pattern (mm)
MKRS000020	200	465
MKRS000040	400	665
MKRS000050	500	765
MKRS000055	550	815
MKRS000060	600	865
MKRS000065	650	915
MKRS000070	700	965
MKRS000080	800	1,065
MKRS000090	900	1,165
MKRS000100	1,000	1,265
MKRS000110	1,100	1,365

6.3

Flat roof installation

- Wind pressure requires binding the collector to the roof
- The wind pressure can be approximated by:

$$\text{Pressure} = \frac{1}{2} \times (\text{density of air}) \times (\text{wind speed})^2 \times (\text{shape factor})$$
- The density of air is about 1.25 kg/m³. The shape factor (drag coefficient) depends on the shape of the body. It has order of magnitude 1 and it is dimensionless; here it is approximated as 0.6
- The wind speed must be expressed in m/s. In that case the pressure has units of kg/m/s², i.e. N/m²
- In case of 40 m/s wind speed=> wind pressure=0.5x1.25x40x0.6=600 [N/m²]=600 [pa]
- This pressure requires a support of approximately 60 kg for every square meter mounted in a 45° on a flat roof

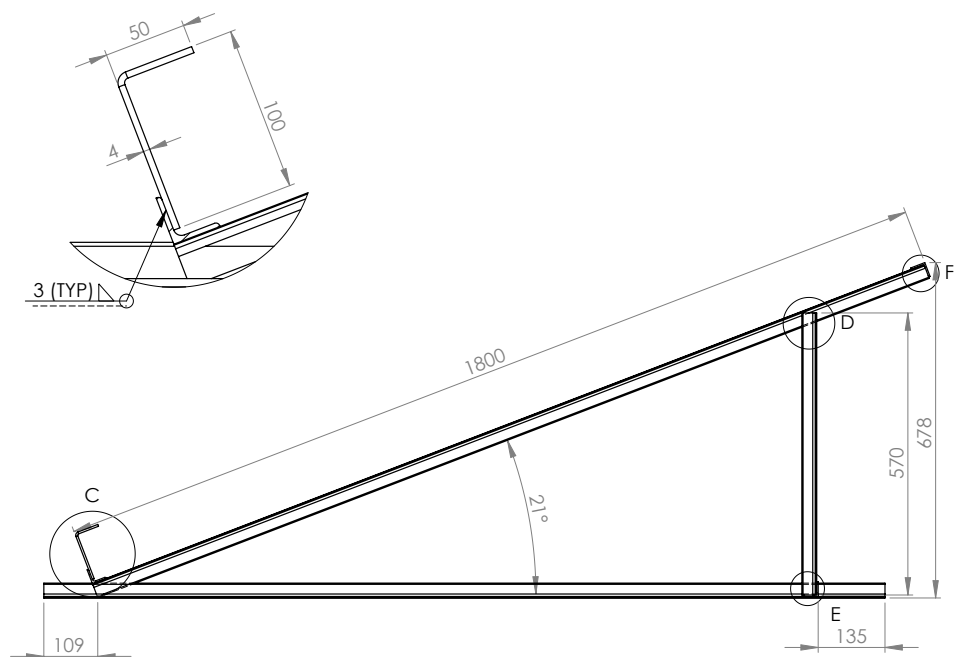

No.	Part no.	Description	QTY.
1	MPGAR30030	L profile 30x30x3x1430	2
2	MPGAR30031	L profile 30x30x3x1800	2
3	MPGAR30032	L profile 30x30x3x850	2
4	MPGAR30033	L profile 30x30x3x970	1
5	MPGAR30034	L profile 30x30x3x1,700	2
6	MPGFR44010	Flat profile 40x4x150	2

6.4

Collectors field installation

Large forced circulation systems require larger collectors field.

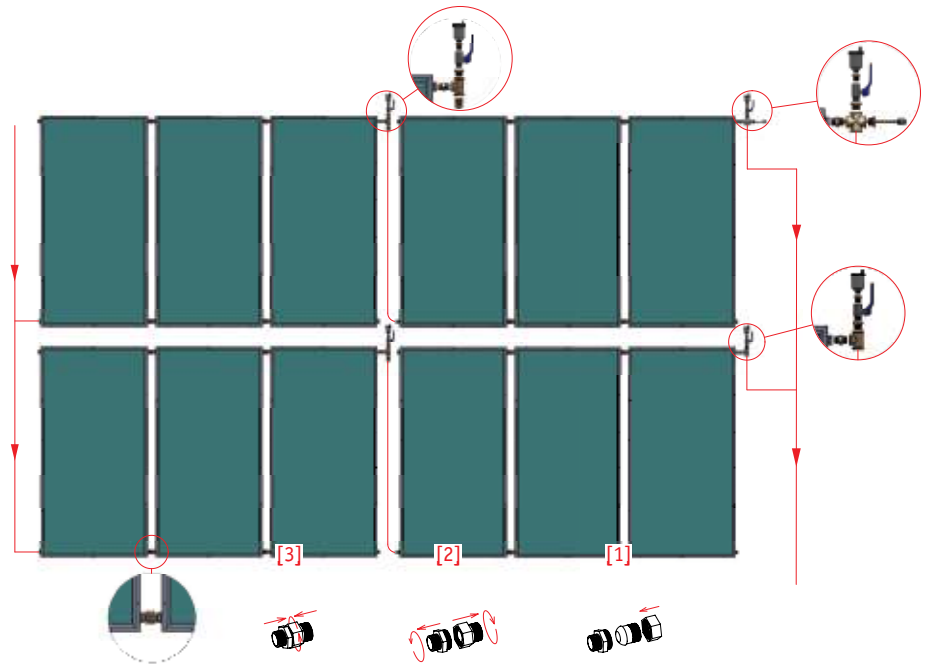

The collectors are regularly connected to each other with 3/4" brass unions.

6.5

Location of collectors, tank and system's operation

The collectors should be placed facing south or north, depending on the earth's latitude and slope, as explained in section 4.7. The tank should be placed as close as possible to the collectors, to avoid heat loss. The recommended pump should match the hot water circulation and a flow of 50-100L per hour per 1m² of collectors' area.

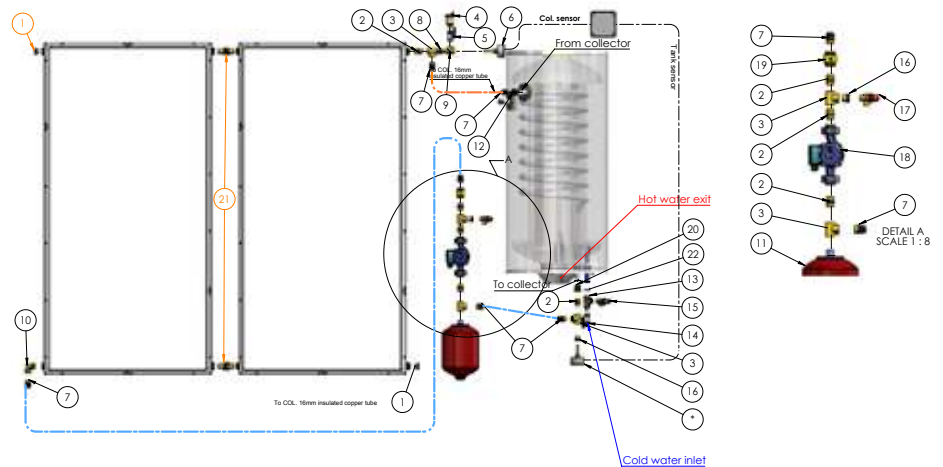

No.	Cat. no.	Description	QTY.
1	QPKKBR0341	3/4" M brass plug	2
2	INIPBR0010	Brass HEX nipple 3/4"	5
3	ITIIBN0020	Brass T 3/4"	4
4	IMSHAV0010	Automatic air relief 1/2"	1
5	IBRZMF0070	Ball valve 1/2" M-F	1
6	ITMDIF0120	Differential thermostat	1
7	IMAHB00027	Brass 3/4" M copper tube connector	6
8	INIPBR0030	Brass reducing nipple 3/4"-1/2"	1
9	ITIIBN0010	Brass T 1/2"	1
10	IZAVBR0030	Brass street elbow 3/4" FM	1
11	IXPTNK0008	Expansion vessel 8L	1
12	IMAAST0080	Sacrificial element adapter 3/4"	1
13	ISHSAL0010	Brass check valve 1/2"-3/4"	1
14	IBRZFF0010	Ball valve 1/2" F-F	1
15	ISHSBI0021	1/2x1/2" solar safety valve	1
16	IBSHBR0010	Brass bushing 3/4-1/2"	2
17	ISHSBI0010	Brass pressure relief valve 1/2"	1
18	IPMPGRN021	UPS 25-20 with a record	1
19	ISHSAL0030	Brass check valve 3/4"	1
20	IMAAST0095	Galvanized painted coupling 3/4"	1
21	IRECBR0010	Brass union 3/4"	2

6.6 Anti-freeze protection

The system is double anti-freeze protected. The heat transfer liquid is a solution of propylene glycol and water, and the pump circulates warmer heat transfer liquid through the collector in freezing conditions. Anti-freeze protection is essential for all solar systems as a single freeze can destroy a collector.

6.7 Plumbing

Follow the installations details as explained in section 5.4.

Use the following guidelines:

- Water feed to the tank should be through a ball valve and a check valve
- Pump must be installed on the cold line, which runs between the lower part of the tank to the lower inlet of the collector(s) and a check valve must be installed next to the pump
- To allow pump service, install ball valves before and after the pump
- All pipes in the circulation line should be 16/18mm copper, water-quality pipes
- Pipes lengths shall be adjusted to the specific installation. Shortest pipes should be used to minimize unwanted heat loss
- Best performance will be achieved with insulated pipes. The hot line from the collectors must be insulated
- For safety reasons a system should be provided with blow-off lines wherever steam or hot fluid can escape

6.8

Electrical connections

It is recommended to put the differential thermostat in an electrical box with a switch and fuses. The box should be accessible for maintenance and easy to operate.

A qualified electrician should perform all wiring according to local codes. The wiring from the differential thermostat to the sensors carries a very low voltage and is not dangerous when wired correctly.

Notes

- A discharge pipe may be connected in a continuously downward direction in a frost free environment and open to the atmosphere
- It is necessary to install a pressure reducing valve, if the water supply pressure exceeds the rated pressure
- The recommended flow rate of the collector loop is 50-100 L/hr m² of absorber surface



7 Troubleshooting and Maintenance



7.1

Thermosiphon system troubleshooting

Problem	Probable cause	Corrective action
Not enough hot water	[1] Shadow on the collectors	[1] Remove obstruction
	[2] Incorrect piping	[2] Re-pipe
	[3] Clogging pipes	[3] Clean pipes
	[4] Tank blocked with sediment	[4] Clean
	[5] System not leveled	[5] Level
	[6] Ruptured tank jacket	[6] Replace tank
	[7] Air trapped in circulation pipes	[7] Purge air
	[8] Not enough liquid in the closed loop	[8] Fix leaks and fill up

7.2

Forced circulation systems troubleshooting

Problem	Probable cause	Corrective action
Pump is not working	[1] Electrical fault	[1] Check electrical connections
	[2] Burnt motor or fuses	[2] Replace
	[3] Cloudy weather, not enough temperature to operate thermostat	[3] No action required. The system is working
	[4] Differential thermostat is not working	[4] Repair or replace
	[5] Faulty sensor	[5] Replace
Pump working incorrectly	[1] Working non-stop	[1] Check differential thermostat
	[2] Air trap	[2] Purge air
	[3] Faulty sensors	[3] Replace
	[4] Differential thermostat does not begin to work	[4] Repair or replace thermostat
No water circulation	[1] Water taps in circulation line are closed	[1] Open
	[2] Air trapped in circulation loop	[2] Purge air
	[3] Blockage in circulation loop piping	[3] Clear blockage
	[4] Piping diameter too small causing high pressure drop	[4] Replace with wider diameter piping
No hot water	[1] Pump is not operating	Check all accessories, air vents, one way valves, filling system of jacket
	[2] Air trapped in circulation loop	
	[3] Frozen or leaking pipes	
	[4] Pump circulates during cloudy days or night due to faulty sensors	
Circulation Pump operating non-stop	[1] Control switch in manual position	[1] Set switch to automatic position
	[2] Air trapped in solar circulation loop	[2] Release air via air vent valves installed in collectors array
	[3] Defective differential thermostat	[3] Check the differential thermostat. Replace if necessary
	[4] Faulty sensor(s)	[4] Check sensor(s) with Ohmmeter. Replace if necessary

WARNING! These systems are electrically powered. Take necessary precautions to avoid electrical shock.

Problem	Probable cause	Corrective action
Pump operating at night or when there is lack of solar radiation during the day due to cloudiness	[1] Control switch in manual position	[1] Set control switch to automatic mode
	[2] Water not circulating in the solar circulation loop	[2] See next section
	[3] Check valve is stuck in open position causing thermosiphon flow in circulation loop	[3] Strike check valve lightly with plastic hammer or wooden rod
	[4] Defective differential thermostat	[4] Repair or replace
Pump operating but water does not circulate in the circulation loop	[1] Water taps in circulation loop are closed	[1] Open water taps
	[2] Air trapped in circulation loop	[2] Purge air
	[3] Check valve is stuck in closed position	[3] Strike valve with plastic hammer or wooden rod
	[4] Check valve installed in the wrong direction	[4] Install valve in proper flow direction
	[5] Incorrect piping installation in circulation loop	[5] Install piping correctly
	[6] Circulation loop pipe clogging	[6] Locate blockage and clean or replace pipe
	[7] Bent or dented pipes	[7] Replace damaged section of pipe
	[8] Main pipe with too small diameter causes high pressure drop	[8] Use larger pipe diameter
Circulation pump does not operate	[1] Control switch in OFF position	[1] Set control switch to Automatic
	[2] Burnt fuse	[2] Check if fuse is suitable for pump power, change fuse, check that pump shaft is not stuck
	[3] Defective differential thermostat	[3] Repair or replace
	[4] Faulty temperature sensors	[4] Check sensors with ohmmeter. Replace if necessary
	[5] Faulty pump motor	[5] Replace pump motor
	[6] Pump receiving no power supply	[6] Check if voltage supply is reaching pump connections
	[7] Burnt transformer in the differential thermostat	[7] Change differential thermostat. Check that the voltage supply is not more than $110V \pm 20V$
	[8] Collectors are covered with dust	[8] Wash the collectors
Pump operating with long delay	[1] Collector's temperature sensor is installed outside the collector's header	[1] Install sensor as deep as possible inside the collector header
	[2] Tank's temperature sensor is installed too high in the tank	[2] Install the sensor at the bottom of the tank
	[3] Wrong controller setting	[3] Consult with Chromagen technical staff
Pump repeatedly starts and stops	[1] Air-bound system	[1] Purge air out of system-ensure pipes slope
No circulation	[1] Air bound pump	[1] Purge air out of system
	[2] Broken pump coupler	[2] Replace; check alignment
	[3] Clogged impeller or piping	[3] Locate and remove obstruction
	[4] System valve closed	[4] Open
	[5] Incorrect pump electrical-circuit	[5] Check all related low and line voltage circuits

Problem	Probable cause	Corrective action
Inadequate Circulation	[1] Air-bound system	[1] Purge air out of system - ensure pipes slope
	[2] Air-bound pump	[2] purge air out of system
	[3] Clogged impeller or piping	[3] Locate and remove obstruction
	[4] Clogged strainer	[4] Remove and clean screen
	[5] Pump impeller damaged or backwards	[5] Replace or re-assemble
	[6] Insufficient NPSH	[6] Lower pump, raise pressure or relocate
	[7] Pump too small	[7] Replace pump
	[8] Partially air-bound pump	[8] Purge air out of system
	[9] Pump running backwards (three-phase)	[9] Reverse any two motor leads
	[10] Improper motor speed	[10] Check wiring and voltage
Pump or system noise	[1] Trapped air	[1] Vent system
	[2] Pump cavitation	[2] Lower pump or raise pressure or relocate
	[3] Excessive water velocity	[3] Install balancing cocks or parallel piping
	[4] Poor foundation	[4] Provide rigid foundation with adequate grouting
	[5] Pipe vibration	[5] Provide adequate pipe support or change pipe length
Premature failure of pump components	[1] Improper pump (size/type)	[1] Replace
	[2] Improper pump location	[2] Relocate
	[3] Excessive water treatment	[3] Check manufacturers instructions
	[4] Unbalanced pump operation	[4] Balance system
	[5] Excessive piping load	[5] Provide proper pipe support

If troubleshooting fails, please contact your local dealer or Chromagen's head office

7.3 Maintenance

This following section covers scheduled inspections, maintenance, and detailed procedures for dismantle and repair of the system. **Only qualified personnel should perform periodic maintenance.**

7.4

Periodic maintenance

- Check the system pressure every 6 months. Pressure reduction might indicate a leak. The pressure should remain above 1 bar. If necessary, pressurize again and check for leaks
- Every 3-6 months clean the collectors' glazing and trim any surrounding trees that might cast a shadow on the collectors
- Every 12 months flush all safety valves. Pressure relief device failure may result in excessive pressure and system damage. Continuous leakage from the valve may indicate excessive heat or defective valve
- Flush and refill collectors in open-loop systems every 12-18 months
- Drain tank if necessary: the cold water inlet is generally the lowest pipe in the tank. Close the main supply, disconnect pipe and open the tanks' hot water outlet for air to come in while draining
- Replace anodes and safety valves every 3 years
- Every three to five years qualified personnel must check electrical connections (pumps, thermostats, switches and wiring)
- Every 3-5 years replace anti-freeze

7.5

Parts replacement

When replacing parts, which are supplied by Chromagen, for example: collector glass, complete collector, tank flange etc., always use Chromagen original parts in order to keep the warranty valid.

7.6

Warnings

A thermal cut-out might indicate a dangerous situation. Do not reset the "Bipolar Safety" of the thermostat until the water heater has been serviced by a qualified person.

WARNING! If the hot water system is not used for two weeks or more, a quantity of hydrogen gas, which is highly flammable, may accumulate in the water heater. To dissipate this gas safely, it is recommended that a hot tap be turned on for several minutes at a sink, basin or bath, but not at a dishwasher, clothes washer or other appliance. During this procedure, there must be no smoking, open flame or any electrical appliance operating nearby. If hydrogen is discharged through the tap, it will probably make an unusual sound like escaping air.

For safety reasons a system should be provided with blow-off lines wherever steam or hot fluid can escape.





8 Accessories



8.1

Thermostatic control

Chromagen supplies solar systems which include thermostatic control. Thermostatic control manual can be found attached to the product. Chromagen tested and approved the use of the thermostatic control supplied with the system. English manual version can be downloaded from the supplier's web site.

8.2

Circulation pumps

- A Forced circulation system uses a pump to move hot water or propylene glycol from the collector down to the tank
- The water or glycol circulation through the collectors can reach temperatures as high as 130°C, therefore only pumps that are designed to operate with hot water may be used
- Selecting a pump is based on the calculated head loss of the collectors loop measured in meters of water and the required flow rate. A nominal flow rate of 50 L/hr per square meter of collectors aperture area may be taken

For example, a system with two Chromagen E (CR-110) collectors with aperture area of 2.15 m², each one requiring a flow rate of 4.3×50=215 L/hr. The losses over the collectors may be taken as 2×7=14cm and the losses through 20m of 16mm copper tube at 250 L/hr are approximately 60cm. Taking into account the loss over an internal heat-exchanger and the minor losses over the plumbing accessories, we can assume 1m head loss over the collectors loop.

The pump supplied by Chromagen, at its lowest speed, should easily generate the required flow rate for this system.



8.3

Thermostatic mixing valve

Thermostatic mixing valve is fitted between the solar water heaters hot water outlet pipe and the home hot water piping system. Its purpose is to ensure that water temperature does not exceed 50°C in order to avoid burns and piping damage.

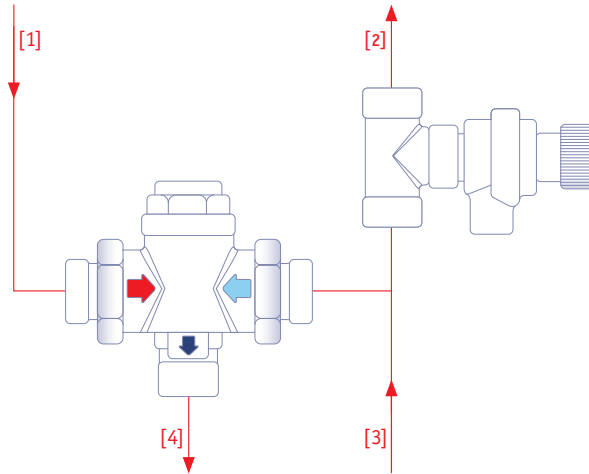

- [1] Tank's hot water outlet
- [2] Tank's cold water inlet
- [3] Cold water supply
- [4] Controlled hot water to user

8.4

Anti-scale filter

The anti-scale filter protects open-loop systems from scale build up. This antiscala filter is a plastic filter containing polyphosphate (siliphos) crystals. Siliphos reduces the amount of scale deposits by keeping the minerals, which cause scale, in a dissolved and suspended state at higher temperatures. As a result, most scale-causing minerals pass through the system instead of forming scale deposits near the heating element or in the collector.

Siliphos is classed as a 'food grade' additive which conforms to EN1208 and WHO standards as a safe additive for drinking water. Therefore it can be installed directly on the cold water supply to the tank, and the customer can safely bath in or even drink the water that has passed through the filter.

Siliphos reduces its volume in proportion to the amount of water passing through the anti-scale filter which will vary according to specific domestic circumstances. The siliphos should be changed according to the filter model maintenance instructions.





Warranty

- [a] During the Warranty Period, Chromagen shall, at Chromagen's option, repair, replace or give credit for any component that is returned to an authorized service center and that is found by Chromagen to contain defects in material or workmanship and returned by distributor to Chromagen; and the extent of Chromagen liability shall not exceed the cost of repairing or replacing the defective item during the warranty period.
- [b] This Warranty does not cover defects or damages resulting from accident, inappropriate physical or operational environment, failure of electrical power, freezing, corrosion, scaling due to hard water, improper installation, maintenance, service, repair, transportation, storage, modification, operation, use, negligence or fault by any party other than Chromagen.
- [c] This Warranty shall run solely to and in favor of the distributor; and the distributor shall be responsible to its customers for all warranties that it makes.
- [d] This Warranty is the sole warranty given by Chromagen in respect of the products.
- [e] In no event shall Chromagen be liable for special, incidental, or consequential damages, or for damages arising out of the inability to utilize products for any purpose whatsoever.
- [f] For warranty period information, please contact Chromagen's distributor in your area.

Index

Glossary of terms

Abbreviation	Corrective Action
COL.	Collector
cm	Centimeter
D.J.	Double-Jacket
DIAG.	Diagonal
F	Female
GL	Gallon
hr	Hour
Kcal	Kilo Calories
Kg	Kilogram
Kw	Kilowatt
L	Liter
lbs	Libras
M	Male
m	Meter
mm	Millimeter
N	Narrow
PRESS.	Pressure
QTY.	Quantity
TEMP.	Temperature
TLSCPc	Telescopic
Vol.	Volume



The Right Choice

EVERY HOUR
EVERY DAY



Chromagen Sha'ar Ha'amakim 3658800, Israel
Tel. +972 4 953 8800 | www.chromagen.com
