

300L horizontal storage tank  
Double jacket heat exchanger  
Aluminium external envelope

- 1 | **External Coating** | Polyester coating provides extreme durability and an attractive finish.
- 2 | **Insulation** | A thick polyurethane insulation layer ensures optimal insulation and heat retention.
- 3 | **Storage Tank** | Constructed with thick steel, automatically welded, ensuring precision and permitting a working pressure of 8 bar.
- 4 | **Enamel Coating** | An internal glass-enamel layer protects against corrosion.
- 5 | **Electric Element** | Energy-efficient electric element with rapid heating time enables the provision of hot water 24 hours a day, 365 days a year.
- 6 | **Sacrificial Anode** | Magnesium Anode provides anti-corrosion protection to the pressure vessel.
- 7 | **Thermostat** | A built-in thermostat ensures that the water temperature inside the tank does not exceed a preset temperature, while using the electric heating element.
- 8 | **Double Jacket Heat Exchanger**
- 9 | **Cold Water Inlet**
- 10 | **Hot Water to User**
- 11 | **Heat Exchanger Inlet**
- 12 | **Heat Exchanger Outlet**
- 13 | **Heat Exchanger Safety Valve**
- 14 | **\* Auxiliary Heating Inlet**

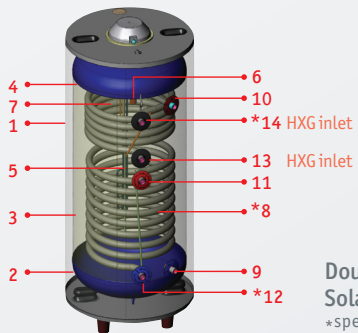

Double Spiral  
Solar Water Tank  
\*specific for this tank only

## Chromagen's Tanks:

	Capacity (l)	Dimensions (HxD) (mm)	Weight (kg)	Electric Element (watt)
Solar Tanks	120	860X560	46	2.5/ None
	150	1020x560	53	
		1480X477	73	
	200	1270x560	65	
	300	1430x650	91	2.5/ 3/3.6/ None
Solar & Electric Tanks with Double Jacket Heat Exchanger	100	1075x477	71	1.8/2/2.5/ None
	120	1250x477	74	
	150	1020x585	75	
	200	1270x585	93	
	300	1430x690	133	2.5/ 3/3.6/ None

	Capacity (l)	Dimensions (HxD) (mm)	Weight (kg)	Electric Element (watt)
Single Spiral Tank				
120	860x585	74	2.5/ None	
	1250x477	78		
150	1020x585	75		
	1480X477	88		
200	1280x585	90	2.5/3/3.6/ None	
300	1430x650	133		
Double Spiral Tank				
200	1280x585	108	2.5 / None	
300	1430x650	145	2.5/ 3/3.6/ None	
Solar & Electric Tanks with Spiral Heat Exchanger	30	670x360	23	1.8/2/2.5
	45	885x360	29	
	60	740X477	31	
	80	930X477	40	
	120	860X565	46	
	120	1260X477	50	
	150	1020X585	65	
	200	1280x585	91	
300	1430x650	100		

### Electric Tanks

- Tanks for horizontal or vertical mounting are available. All tanks are tested at a pressure of 12 bar, with a permitted working pressure of up to 8 bar.
- Due to on-going developments, specifications are subject to changes without early notice.



(\* Storage tanks weight refers to painted galvanized envelope and common heat exchanger size. Tanks weight might change due to envelope type change or heat exchanger size change upon request.

# WATER HEATERS

Chromagen is a leading international manufacturer of solar and electric water heaters, combining the most advanced technology and traditional heating methods. Our products incorporate state-of-the-art engineering, rugged construction and select materials, resulting in efficient and durable products.



## About Us

Chromagen, a pioneer in the production of solar water solutions since 1962, is the market-leader in Israel, which leads the world in per capita installations. Globally, the company has developed a solid install base, increasing supply and demand annually. Chromagen's systems, which are available in more than 35 countries worldwide, bring innovation, quality and cost savings to home owners, institutions and commercial projects. The commitment to deliver top-of-the-line water-heating solar solutions is in conjunction with the belief to promote environmental awareness.



**Best-in-class**  
clean hot water solutions



**Environmental health**



**Energy efficiency**



**Customer service**



**Product innovation**

designshoot: B18012010152310 @ 2010 Chromagen. Subject to change without notice.

